

A free boundary problem involving a cusp: breakthrough of salt water

H. W. ALT

Institut für Angewandte Mathematik, Universität Bonn, Wegelerstrasse 6, 5300 Bonn 1, Germany

C. J. VAN DUIJN[†]

Centrum voor Wiskunde en Informatica, Kruislaan 413, 1098 SJ Amsterdam, The Netherlands

[Received 23 October 1998]

In this paper we study a two-phase free boundary problem describing the stationary flow of fresh and salt water in a porous medium, when both fluids are drawn into a well. For given discharges at the well (Q_f for fresh water and Q_s for salt water) we formulate the problem in terms of the stream function in an axial symmetric flow domain in \mathbb{R}^n ($n = 2, 3$). We prove the existence of a continuous free boundary which ends up in the well, located on the central axis. Moreover, we show that the free boundary has a tangent at the well and approaches it in a C^1 sense. Using the method of separation of variables we also give a result concerning the asymptotic behaviour of the free boundary at the well. For a given total discharge ($Q := Q_f + Q_s$) we consider the vanishing Q_s limit. We show that a free boundary arises with a cusp at the central axis, having a positive distance from the well. This work is a continuation of [5, 6].

Keywords: Porous media flow; free boundary problem.

1. Introduction

In two previous papers [5, 6], we studied a free boundary problem that results from a model describing the withdrawal of fluid from a reservoir. In that model we considered the stationary flow of two incompressible fluids through a homogeneous and isotropic porous medium (the reservoir). The fluids have constant but different densities and are assumed to be separated by an abrupt transition, **an interface**. In the reservoir one or more wells are present to recover one of the fluids. Such models are relevant, for instance, when designing freshwater reservoirs in coastal regions. Then fresh water overlays salt water from the sea.

When we think of a horizontal interface in the absence of the wells, we will observe an upconed interface after applying the wells to the fluid on top, see Fig. 1, where a reservoir with only one well is shown.

Assuming only horizontal flow along the vertical boundaries of the reservoir, with a fixed and prescribed position of the interface (u_0), a stationary flow and a stationary interface may result for which the fluid below is stagnant. The fluid on top is drawn into the wells. This case is studied in detail in [5]. It leads to an elliptic free boundary problem involving a parameter Q , which is related to the withdrawal rate or discharge of the wells. It was shown that a critical rate $Q_{cr} > 0$ exists such that for $Q < Q_{cr}$ the interface can be represented by an analytic function of the horizontal coordinates. Moreover, the height of the interface increases whenever the rate increases. At $Q = Q_{cr}$ a cusp develops in the interface, being still at a positive distance from the well, see Fig. 2. These results were proven for flows in \mathbb{R}^n , $n \geq 2$.

[†] Author to whom correspondence should be addressed.

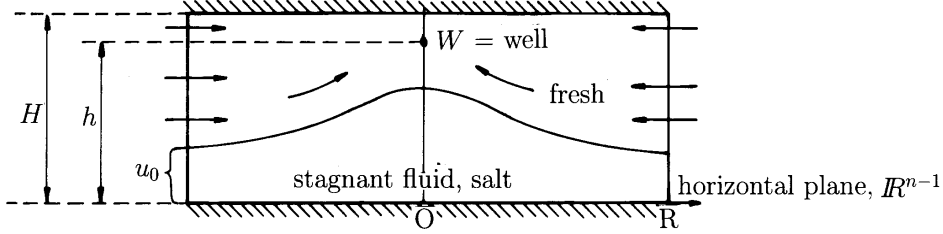
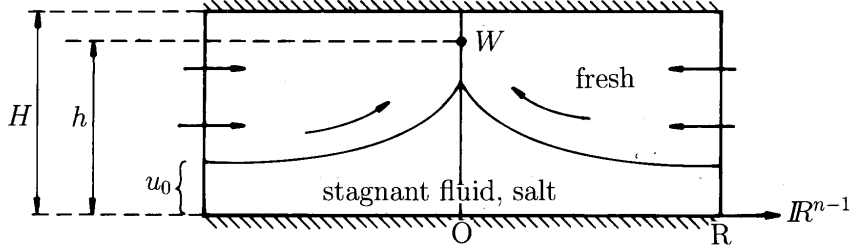
FIG. 1. Smooth upconed interface, $Q < Q_{cr}$.FIG. 2. Interface with cusp, $Q = Q_{cr}$.

In the second work [6], we analysed in detail the local behaviour near the cusp. This was performed for the two-dimensional case ($n = 2$) only. Applying our local results to a configuration with one well, as in Fig. 2, we obtain for points (x, z) on the interface (x horizontal, z vertical) near the cusp (x_0, z_0)

$$\lim_{x \rightarrow x_0} \frac{|x - x_0|}{(z_0 - z)^{3/2}} = C$$

for some constant $C > 0$.

Keeping the reservoir dimensions (H and R) and all physical parameters fixed, the value of the critical rate Q_{cr} only depends on $h - u_0$, where h denotes the distance between the well and the bottom of the reservoir. We conjecture that $Q_{cr} = Q_{cr}(h - u_0)$ is continuous and strictly increasing with $Q_{cr}(0) = 0$.

Instead of considering the critical cusp case as the limit of subcritical cases, all having smooth interfaces with stagnant salt water below, we propose in this paper a different strategy. In this strategy we let the salt water move as well and we characterize the cusp case as the limit of vanishing flow in the saltwater region.

Thus we first need to address the problem of what happens when the salt water also moves towards the well. We expect a fluid distribution as in Fig. 4.

The main result of this paper is that there are stationary solutions of this type. We study these

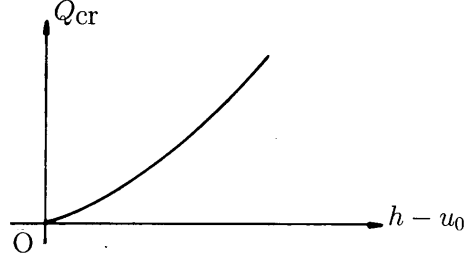

FIG. 3. Sketch of the behaviour of Q_{cr} ; the shape of the curve is unknown.

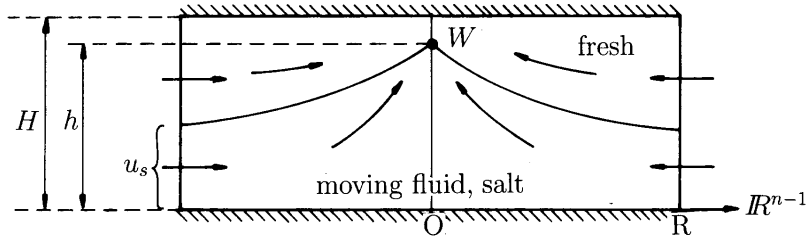

FIG. 4. Salt water moves towards the well.

solutions for axial symmetric flows ($n = 2, 3$), with only one well on the central axis. This allows us to formulate the problem in terms of a stream function, as in [2] or [4].

In Section 2 we present the weak formulation for the flow problem in a bounded, axial symmetric reservoir of constant thickness. Now the formulation involves two parameters: Q_s (outflow of salt water at the well) and Q_f (outflow of fresh water at the well), or rather Q_s and $Q := Q_s + Q_f$ (total outflow at the well). As a result of this formulation we are able to prove that a weak solution exists (Section 3). In Section 4 we show that the interface is a continuous curve in the z -direction. On the axis it ends up in the well W and on the lateral boundary in a well-defined point (R, u_s) .

In Sections 5 and 6 we consider the free boundary near the well. First, we show in Section 5 that the free boundary has a tangent at W and approaches it in a C^1 -sense. The tangent direction is given by the angle

$$\omega_* = \begin{cases} \frac{\pi}{2} \frac{Q_s - Q_f}{Q_s + Q_f} & \text{for } n = 2, \\ \arcsin \frac{Q_s - Q_f}{Q_s + Q_f} & \text{for } n = 3, \end{cases}$$

with respect to the horizontal plane. Note that ω_* only depends on the discharge at the well and does not involve density (gravity) effects. The asymptotic behaviour at W is studied in Section 6.

Introducing polar coordinates and writing, for free boundary points (r, z) ,

$$r + i(z - h) = e^{s+i\omega(s)},$$

we give by means of the method of separation of variables an estimate for the rate of convergence (see Theorem 6.7)

$$\omega(s) \rightarrow \omega_* \text{ as } s \searrow -\infty.$$

Concerning the vanishing Q_s limit we only have a partial result. In Section 7 we show that if Q is sufficiently small, depending only on the reservoir dimensions and the position of the well, then $Q_s \searrow 0$ results in an interface with a cusp at the origin, having a positive distance from the well, and with stagnant fluid below it. For larger values of Q we have no precise mathematical results when taking this limit. However, we conjecture the following behaviour: if $Q \leq Q_{cr}(h)$, see Fig. 3, then $Q_s \searrow 0$ results in a decreasing sequence of interfaces, converging to a cusped interface satisfying $Q_{cr}(h - u_0) = Q$, where $u_0 = \lim_{Q_s \searrow 0} u_s$. Only for $Q < Q_{cr}(h)$ is this rigorously demonstrated.

If $Q > Q_{cr}(h)$, then $Q_s \searrow 0$ results in a decreasing sequence of interfaces converging to a cusped interface which partly coincides with the horizontal bottom of the reservoir, see Fig. 5.

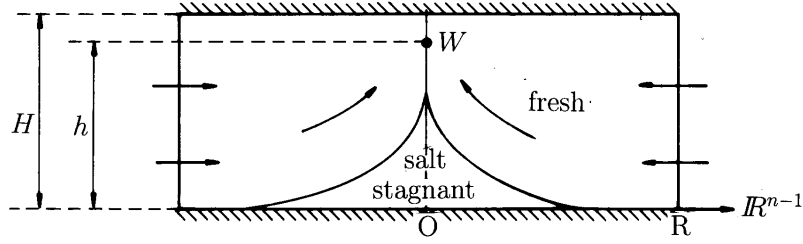

FIG. 5. Conjectured interface for $Q > Q_{cr}(h)$.

In the two-dimensional setting such interfaces have been constructed explicitly using hodograph techniques, for example, see [12].

2. Formulation of the problem

Let the reservoir occupy the bounded, axial-symmetric region

$$\tilde{\Omega} = \left\{ (x_1, \dots, x_n) : \sqrt{x_1^2 + \dots + x_{n-1}^2} < R, 0 < x_n < H \right\},$$

with $n = 2, 3$ describing the physical cases. It is saturated by either fresh water or salt water, which are macroscopically separated by an interface S . We also write

$$\tilde{\Omega} = \tilde{\Omega}_f \cup S \cup \tilde{\Omega}_s,$$

where $\tilde{\Omega}_f$ and $\tilde{\Omega}_s$ denote the regions filled up by the fresh and salt groundwater, see Fig. 6.

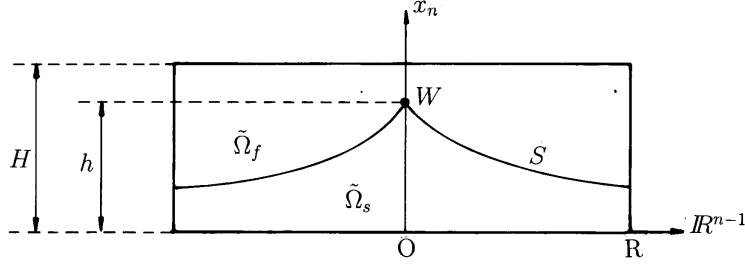

FIG. 6. Axial symmetric reservoir.

At the central axis, a well W is located at a distance $h \in]0, H[$ above the horizontal plane $\{x_n = 0\}$. We will study the case where both fresh and salt water are being extracted from the reservoir through W . Let $Q_f > 0$ denote the discharge of fresh water and $Q_s > 0$ the discharge of salt water. Then $Q := Q_s + Q_f$ is the total production rate of fluid from the reservoir. Each fluid has a constant specific weight γ_i , with $0 < \gamma_f < \gamma_s < \infty$ and the fluid-medium interaction is characterized by a constant mobility $\lambda > 0$. The model is described by Darcy's law

$$q + \lambda(\text{grad } p + \gamma e_z) = 0$$

and the fluid balance equation

$$\text{div } q = -Q \delta_W$$

in $\tilde{\Omega}$, where $\gamma = \gamma_f$ in $\tilde{\Omega}_f$ and $\gamma = \gamma_s$ in $\tilde{\Omega}_s$. In these equations, q denotes the specific discharge, p the pressure, e_z the unit vector in the positive x_n -direction (against the direction of gravity) and δ_W the Dirac distribution at the point W . Along the upper and lower boundary of $\tilde{\Omega}$ we require a no-flow condition, expressed by

$$q \cdot e_z = 0 \quad \text{on } \{x_n = 0\} \cup \{x_n = H\}.$$

Along the cylindrical, lateral boundary we assume horizontal flow, i.e.

$$q \text{ is normal at } \{x_1^2 + \dots + x_{n-1}^2 = R^2\}.$$

Because of the cylindrical form of the reservoir and the central location of the well, we expect axial symmetry of the unknowns. Thus introducing

$$r = \sqrt{x_1^2 + \dots + x_{n-1}^2} \quad \text{and} \quad z = x_n,$$

we consider p , q and γ to be functions of these variables. We obtain in the two-dimensional domain

$$\Omega = \{(r, z) : 0 < r < R, 0 < z < H\}$$

Darcy's law again

$$q + \lambda(\nabla p + \gamma e_z) = 0, \tag{2.1}$$

where now $q = q_r e_r + q_z e_z$, with $e_r = \frac{1}{r}(x_1, \dots, x_{n-1}, 0)$ and $e_z = (0, \dots, 0, 1)$, and $\nabla = (\partial_r, \partial_z)$. The fluid balance equation in Ω becomes

$$\frac{1}{r^{n-2}} \partial_r (r^{n-2} q_r) + \partial_z q_z = 0.$$

The latter equation suggests the introduction of a stream function $\psi : \Omega \rightarrow \mathbb{R}$ satisfying

$$q = \left(-\frac{1}{r^{n-2}} \partial_z \psi, \frac{1}{r^{n-2}} \partial_r \psi \right). \quad (2.2)$$

At this point we first introduce dimensionless variables. Let $\Gamma = \lambda(\gamma_s - \gamma_f)$. Then we normalize

$$\psi := \psi / (\Gamma H^{n-2}); \quad Q, Q_s \text{ and } Q_f \text{ similar}$$

$$\gamma := (\gamma - \gamma_f) / (\gamma_s - \gamma_f)$$

$$r = r/H; \quad z, H, R \text{ and } h \text{ similar.}$$

An equation for ψ results by taking the two-dimensional curl of Darcy's law (2.1) and by substituting (2.2) into the result, see also [2] or [4]. This yields

$$\nabla \cdot \left(\frac{1}{r^{n-2}} \nabla \psi + \gamma e_r \right) = 0 \quad \text{in } \Omega, \quad (2.3)$$

with

$$\gamma = \begin{cases} 0 & \text{in } \Omega_f, \\ 1 & \text{in } \Omega_s, \end{cases}$$

where Ω_f and Ω_s now denote the subregions of Ω filled up by fresh and salt water, see Fig. 7.

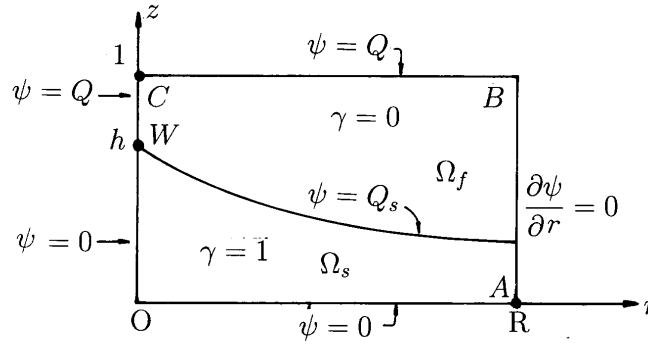

FIG. 7. Boundary conditions for ψ .

Because the top and bottom of the reservoir are impervious, the stream function must be constant there. The same is true on the symmetry axis, except, of course, at the location $(0, h)$ of the well,

where fluid is being extracted from the reservoir. There the stream function exhibits a jump Q . With reference to Fig. 7 we take

$$\psi = 0 \quad \text{along } AOW$$

and

$$\psi = Q \quad \text{along } BCW.$$

The assumption of only horizontal flow along the lateral boundary requires

$$\partial_r \psi = 0 \quad \text{along } AB.$$

For future reference, we denote the boundary of Ω by $\partial\Omega$, the part $AOCB$ by $\partial_D\Omega$ and the part AB by $\partial_N\Omega$. Because the interface is stationary, ψ must be constant there as well. To ensure that the prescribed saltwater discharge Q_s is being extracted from the reservoir we take

$$\psi = Q_s \quad \text{along the fresh-salt interface.}$$

Now considering (2.3) in Ω_f and Ω_s , we expect to find, by the strong maximum principle,

$$0 < \psi < Q_s \quad \text{in } \Omega_s$$

and

$$Q_s < \psi < Q \quad \text{in } \Omega_f.$$

Therefore we write

$$\gamma = 1 - H(\psi - Q_s) \quad \text{in } \Omega,$$

where $H(\cdot)$ denotes the Heaviside graph

$$H(s) = \begin{cases} 1 & \text{for } s > 0, \\ [0, 1] & \text{for } s = 0, \\ 0 & \text{for } s < 0. \end{cases}$$

We expect certain smoothness (at least Lipschitz continuity) away from the location of the well. To capture the singular behaviour of ψ there, we consider the function ψ_0 which corresponds to $\gamma = 0$ in Ω : i.e. it satisfies

$$\nabla \cdot \left(\frac{1}{r^{n-2}} \nabla \psi_0 \right) = 0 \quad \text{in } \Omega \quad (2.4)$$

and the ψ -boundary conditions on $\partial\Omega$.

LEMMA 2.1 *There exists exactly one such ψ_0 , smooth (at least C^1) away from W , with $\partial_z \psi_0 > 0$ in Ω . Near W it satisfies*

$$\psi_0 = \psi_* + \text{smooth terms},$$

where

$$\psi_*(r, z) := \begin{cases} \frac{Q}{2} \left(\frac{2}{\pi} \arctan \frac{z-h}{r} + 1 \right) & \text{for } n = 2, \\ \frac{Q}{2} \left(\frac{z-h}{(r^2 + (z-h)^2)^{1/2}} + 1 \right) & \text{for } n = 3. \end{cases}$$

Proof. We give the proof only for $n = 3$. It uses the pressure formulation in the three-dimensional domain $\tilde{\Omega}$. Let \tilde{p}_0 be the weak solution of the problem

$$\begin{cases} \Delta \tilde{p}_0 = 2\pi Q \delta_W & \text{in } \tilde{\Omega}, \\ \partial_z \tilde{p}_0 = 0 & \text{on top and bottom of } \tilde{\Omega}, \\ \tilde{p}_0 = 0 & \text{on lateral side of } \tilde{\Omega}. \end{cases}$$

By standard elliptic theory, e.g. see [9], there exists a unique \tilde{p}_0 which is smooth outside W . Clearly \tilde{p}_0 is axially symmetric. Therefore, writing $x = (x_1, x_2, x_3)$,

$$\tilde{p}_0(x) = p_0(r, z), \quad \text{with } (r, z) \in \Omega.$$

The function p_0 is smooth inside Ω where it satisfies the equation

$$\partial_r(r \partial_r p_0) + \partial_z(r \partial_z p_0) = 0.$$

Since Ω is simply connected, this implies the existence of a unique (up to an additive constant) function $\psi_0 : \tilde{\Omega} \setminus W \rightarrow \mathbb{R}$ which satisfies

$$\partial_z p_0 = -\frac{1}{r} \partial_r \psi_0 \quad \text{and} \quad \partial_r p_0 = \frac{1}{r} \partial_z \psi_0. \quad (2.5)$$

One easily verifies that ψ_0 solves (2.4) in Ω , that ψ_0 is piecewise constant on $\partial_D \Omega$ (except at W) and that $\partial_r \psi_0 = 0$ on $\partial_N \Omega$. To show that ψ_0 jumps with Q at W we integrate the three-dimensional equation for \tilde{p}_0 over a small cylindrical neighbourhood of W . For $\varepsilon, \delta > 0$ and sufficiently small, let

$$C_\delta^\varepsilon := \left\{ x = (x_1, x_2, x_3) : \sqrt{x_1^2 + x_2^2} < \varepsilon, |x_3 - h| < \delta \right\}.$$

Then

$$\begin{aligned} 2\pi Q &= \int_{\partial C_\delta^\varepsilon} \text{grad } \tilde{p}_0 \cdot \nu \\ &= 2\pi \int_{h-\delta}^{h+\delta} \varepsilon \partial_r p_0(\varepsilon, z) \, dz + \int_{\left\{ \sqrt{x_1^2 + x_2^2} < \varepsilon \right\}} \{ \partial_z \tilde{p}_0(x_1, x_2, \delta) - \partial_z \tilde{p}_0(x_1, x_2, -\delta) \} \, dx_1 \, dx_2. \end{aligned}$$

In the first integral we replace the integrand by $\partial_z \psi_0(\varepsilon, z)$.

Then for δ fixed and $\varepsilon \searrow 0$ we find

$$Q = \psi_0(0, h + \delta) - \psi_0(0, h - \delta),$$

which shows that ψ_0 indeed satisfies the correct jump condition at W . The proof concerning the z -monotonicity of ψ_0 in Ω follows as a special case of the proof of Proposition 3.4. (i.e. without gravity). It will therefore not be given here.

The asymptotic expressions follow from the observation that near W , \tilde{p}_0 can be written as

$$\tilde{p}_0(x) = -2\pi Q F(x - W) + \text{smooth terms},$$

where F is the fundamental solution of $-\Delta$ with respect to the origin. Consequently, near W ,

$$\text{grad } \tilde{p}_0(x) = \frac{Q}{2} \frac{x - W}{|x - W|^3} + \text{smooth terms}$$

or

$$\nabla p_0(r, z) = \frac{Q}{2(r^2 + (z - h)^2)^{3/2}} (r e_r + (z - h) e_z) + \text{smooth terms}.$$

Finally, we use relations (2.5) and obtain

$$\psi_0 = \psi_* + \text{smooth terms near } W,$$

with ψ_* as in the assertion. □

Using ψ_0 we introduce the following weak formulation. Let

$$V = \left\{ \zeta \in H^{1,2}(\Omega) : \zeta = 0 \text{ in } \partial_D \Omega \text{ and } r^{\frac{2-n}{2}} \nabla \zeta \in L^2(\Omega; \mathbb{R}^2) \right\}.$$

Find $\psi \in \psi_0 + V$, $\gamma \in L^\infty(\Omega)$ and $\gamma_N \in L^\infty(\partial_N \Omega)$ such that

$$\int_{\Omega} \nabla \zeta \cdot \left\{ \frac{1}{r^{n-2}} \nabla(\psi - \psi_0) + \gamma e_r \right\} = \int_{\partial_N \Omega} \zeta \gamma_N \quad (*)$$

for all $\zeta \in V$, and

$$\begin{cases} \gamma \in 1 - H(\psi - Q_s) & \text{in } \Omega, \\ \gamma_N \in 1 - H(\psi - Q_s) & \text{in } \partial_N \Omega. \end{cases} \quad (**)$$

REMARK. If the value of γ would exist at $\partial_N \Omega$, and coincide with γ_N , then the weak formulation (at least formally) implies $\partial_r(\psi - \psi_0) = 0$ at $\partial_N \Omega$. Since $\partial_r \psi_0 = 0$ along $\partial_N \Omega$, this gives the desired boundary condition for ψ .

3. Existence of weak solution

LEMMA 3.1 *There exists at least one weak solution $\{\psi, \gamma, \gamma_N\}$.*

Proof. In the equation for ψ we introduce an ε -regularization with respect to γ and, based on the function ψ_0 in Section 2, an ε -regularization with respect to the term $1/r^{n-2}$ in the differential equation, the Dirichlet condition on the axis, and due to the special construction below also with respect to the domain.

The perturbed domain is

$$\Omega_\varepsilon :=]0, R - \varepsilon[\times]0, 1[$$

and the perturbed function

$$\psi_{0,\varepsilon} : \bar{\Omega}_\varepsilon \rightarrow \mathbb{R},$$

is defined by the shift

$$\psi_{0,\varepsilon}(r, z) = \psi_0(r + \varepsilon, z) \quad \text{for } (r, z) \in \bar{\Omega}_\varepsilon.$$

Each function $\psi_{0,\varepsilon}$ is a smooth solution of the perturbed equation

$$\nabla \cdot \left(\frac{1}{(r + \varepsilon)^{n-2}} \nabla \psi_{0,\varepsilon} \right) = 0 \quad \text{in } \Omega_\varepsilon$$

and satisfies the boundary conditions, see Fig. 8,

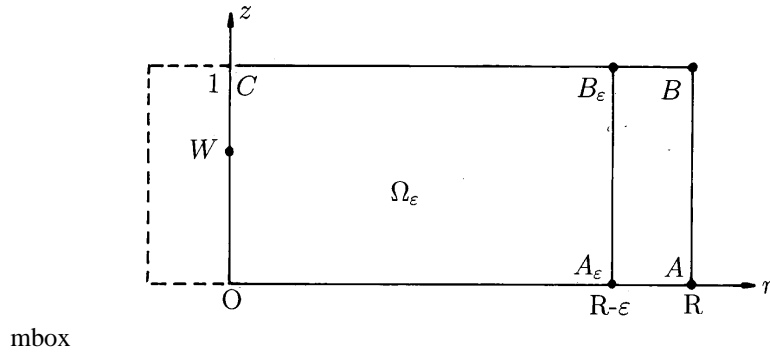

FIG. 8. Shifted domain Ω_ε .

$$BC_\varepsilon \begin{cases} \psi_{0,\varepsilon} = 0 & \text{on } OA_\varepsilon, & \psi_{0,\varepsilon} = Q & \text{on } B_\varepsilon C \\ \partial_r \psi_{0,\varepsilon} = 0 & \text{on } A_\varepsilon B_\varepsilon \\ \psi_{0,\varepsilon} = \psi_0(\varepsilon, \cdot) & \text{on } OC, \end{cases}$$

where $\psi_0(\varepsilon, \cdot)$ satisfies: $\psi_0(\varepsilon, 0) = 0$, $\psi_0(\varepsilon, 1) = Q$, $\partial_z \psi_0(\varepsilon, \cdot) > 0$ and $\psi_0(\varepsilon, z) \rightarrow \psi_0(0, z)$ as $\varepsilon \searrow 0$ pointwise for $z \neq h$ (with $\psi_0(0, \cdot) = 0$ on OW and $\psi_0(0, \cdot) = Q$ on WC), see Lemma 2.1.

Next we turn to the ε -regularization for ψ , which we define through the problems (for any small $\varepsilon > 0$)

$$P_\varepsilon \begin{cases} \nabla \cdot \left(\frac{1}{(r + \varepsilon)^{n-2}} \nabla \psi + (1 - H_\varepsilon(\psi - Q_s)) e_r \right) = 0 & \text{in } \Omega_\varepsilon, \\ \psi \text{ satisfies } BC_\varepsilon, \end{cases}$$

where H_ε is a smooth monotone approximation of the Heaviside graph. As for instance in [1] or [7], Problem P_ε has a unique smooth solution ψ_ε . We first show that Problem P_ε satisfies a comparison principle. \square

PROPOSITION 3.2 *Let ψ_1 and ψ_2 be two solutions of the ψ_ε -equation satisfying $\psi_1 \leq \psi_2$ on $\partial_D \Omega_\varepsilon$ and $\partial_r(\psi_1 - \psi_2) = 0$ on $\partial_N \Omega_\varepsilon$. Then*

$$\psi_1 \leq \psi_2 \quad \text{in } \Omega_\varepsilon.$$

Proof. The proof is a modification of the proof of [11: Theorem 1]. There he tests the equation for the difference $\psi_1 - \psi_2$ with the function (for $\delta > 0$)

$$\zeta = \frac{w}{\delta + w} \quad \text{with } w = (\psi_1 - \psi_2 - \delta)_+.$$

Following this procedure we arrive at the identity

$$\begin{aligned} \delta \int_{\{\psi_1 - \psi_2 \geq \delta\}} \frac{1}{(r + \varepsilon)^{n-2}} \frac{|\nabla w|^2}{(\delta + w)^2} + \delta \int_{\{\psi_1 - \psi_2 \geq \delta\}} (H_2 - H_1) \frac{\partial_r w}{(\delta + w)^2} \\ + \int_{\{\psi_1 - \psi_2 \geq \delta\} \cap \{r=R-\varepsilon\}} (H_1 - H_2) \frac{w}{\delta + w} = 0, \end{aligned}$$

where we used the notation $H_i = H_\varepsilon(\psi_i - Q_\varepsilon)$. The first and second term are as in [11] and can be treated similarly. The third term is non-negative, by the monotonicity of H_ε , and can therefore be disregarded from the estimates. Proceeding as in [11] results in $\psi_1 \leq \psi_2$ in Ω . \square

COROLLARY 3.3 $0 \leq \psi_\varepsilon \leq Q$ in Ω_ε .

Proof. Since constants satisfy the equation, these inequalities follow from BC_ε . \square

Returning to the existence proof we introduce the difference

$$v_\varepsilon := \psi_\varepsilon - \psi_{0,\varepsilon} \quad \text{in } \Omega_\varepsilon,$$

which satisfies the equation, with $h_\varepsilon := H_\varepsilon(v_\varepsilon + \psi_{0,\varepsilon} - Q_\varepsilon)$,

$$\nabla \cdot \left(\frac{1}{(r + \varepsilon)^{n-2}} \nabla v_\varepsilon + (1 - h_\varepsilon) e_r \right) = 0 \quad \text{in } \Omega_\varepsilon$$

and the homogeneous boundary conditions

$$v_\varepsilon|_{\partial_D \Omega_\varepsilon} = 0 \quad \text{and} \quad \partial_r v_\varepsilon|_{\partial_N \Omega_\varepsilon} = 0.$$

Multiplying the equation by v_ε and integrating over Ω_ε gives

$$\int_{\Omega_\varepsilon} \frac{1}{(r + \varepsilon)^{n-2}} |\nabla v_\varepsilon|^2 = - \int_{\Omega_\varepsilon} (1 - h_\varepsilon) \partial_r v_\varepsilon + \int_{\{r=R-\varepsilon\}} (1 - h_\varepsilon) v_\varepsilon.$$

Absorbing the first term in the right-hand side and using Corollary 3.3. for the second term, we obtain the uniform estimate

$$\int_{\Omega_\varepsilon} \frac{1}{(r + \varepsilon)^{n-2}} |\nabla v_\varepsilon|^2 \leq C.$$

Introducing the characteristic function of the set Ω_ε , we deduce

$$\chi_{\Omega_\varepsilon} \frac{\nabla v_\varepsilon}{(r + \varepsilon)^{\frac{n}{2}-1}} \text{ is uniformly bounded in } L^2(\mathbb{R}^2; \mathbb{R}^2),$$

$\chi_{\Omega_\varepsilon} v_\varepsilon$ is uniformly bounded in $L^\infty(\mathbb{R}^2)$.

Consequently, there exist functions $v^* \in L^2(\Omega; \mathbb{R}^2)$ and $v \in L^2(\Omega)$ such that for a sequence $\varepsilon \searrow 0$

$$\chi_{\Omega_\varepsilon} \frac{\nabla v_\varepsilon}{(r + \varepsilon)^{\frac{n}{2}-1}} \rightarrow \chi_\Omega v^* \text{ weakly in } L^2(\mathbb{R}^2; \mathbb{R}^2),$$

$$\chi_{\Omega_\varepsilon} v_\varepsilon \rightarrow \chi_\Omega v \text{ weak star in } L^\infty(\mathbb{R}^2).$$

Since then $\chi_{\Omega_\varepsilon} \nabla v_\varepsilon \rightarrow \chi_\Omega r^{\frac{n}{2}-1} v^*$ weakly in $L^2(\mathbb{R}^2; \mathbb{R}^2)$, it follows that $v \in H^{1,2}(\Omega)$ with

$$\nabla v = r^{\frac{n}{2}-1} v^* \quad \text{a.e. in } \Omega.$$

Therefore $v_\varepsilon \rightarrow v$ weakly in $H_{loc}^{1,2}(\Omega)$ and thus for a subsequence

$$v_\varepsilon \rightarrow v \quad \text{a.e. in } \Omega.$$

Since also $\psi_{0,\varepsilon} \rightarrow \psi$ locally uniformly in $\bar{\Omega} \setminus W$, there exists $\hat{\gamma} \in L^\infty(\Omega)$ such that

$$\chi_{\Omega_\varepsilon} H_\varepsilon(v_\varepsilon + \psi_{0,\varepsilon} - Q_s) \rightarrow \hat{\gamma}$$

weak star in $L^\infty(\mathbb{R}^2)$ with $\hat{\gamma} \in H(v + \psi_0 - Q_s)$, and $\hat{\gamma}_N \in L^\infty(\partial_N \Omega)$ such that

$$H_\varepsilon(v_\varepsilon + \psi_{0,\varepsilon} - Q_s)(R - \varepsilon, \cdot) \rightarrow \hat{\gamma}_N(R, \cdot)$$

weak star in $L^\infty(]0, 1[)$ with $\hat{\gamma}_N \in H(v + \psi_0 - Q_s)$.

Finally, we test the v_ε -equation with $\zeta \in V$. This gives

$$\begin{aligned} \int_{\mathbb{R}^2} \frac{\nabla \zeta}{(r + \varepsilon)^{\frac{n}{2}-1}} \cdot \left(\chi_{\Omega_\varepsilon} \frac{\nabla v_\varepsilon}{(r + \varepsilon)^{\frac{n}{2}-1}} \right) + \int_{\mathbb{R}^2} \partial_r \zeta \chi_{\Omega_\varepsilon} (1 - H_\varepsilon(v_\varepsilon + \psi_{0,\varepsilon} - Q_s)) \\ = \int_{\{r=R-\varepsilon\}} \zeta (1 - H_\varepsilon(v_\varepsilon + \psi_{0,\varepsilon} - Q_s)). \end{aligned}$$

We now have all ingredients to pass to the limit for $\varepsilon \searrow 0$, which gives the weak equation (\star) for $\psi := v + \psi_0$. \square

Crucial for the existence of a free boundary is the inequality.

PROPOSITION 3.4 $\partial_z \psi \geq 0$ in sense of distributions.

Proof. For $\delta > 0$, sufficiently small, we define the domain

$$\Omega_\varepsilon^\delta =]0, R - \varepsilon[\times]\delta, 1[$$

and the translated function

$$\psi_\varepsilon^\delta(r, z) = \psi_\varepsilon(r, z - \delta) \quad \text{for } (r, z) \in \Omega_\varepsilon^\delta.$$

Using the properties of BC_ε and Corollary 3.3 we have

$$\psi_\varepsilon^\delta \leq \psi_\varepsilon \text{ on } \partial_D \Omega_\varepsilon^\delta \text{ and } \partial_r(\psi_\varepsilon^\delta - \psi_\varepsilon) = 0 \text{ on } \partial_N \Omega_\varepsilon^\delta.$$

Since ψ_ε^δ satisfies the ψ_ε -equation as well, the comparison principle gives $\psi_\varepsilon^\delta \leq \psi_\varepsilon$ in $\Omega_\varepsilon^\delta$. From this inequality $\partial_z \psi_\varepsilon \geq 0$ in Ω_ε is immediate. Letting $\varepsilon \searrow 0$ completes the proof. \square

For later use we show continuity properties of the solution ψ .

THEOREM 3.5 ψ is Hölder continuous in $\bar{\Omega} \setminus W$.

Proof. The Hölder continuity away from the axis follows from standard techniques. Since γ_N depends only on the z -variable, the weak equation for ψ can be written as

$$\int_{\Omega} \nabla \zeta \cdot \left(\frac{1}{r^{n-2}} \nabla \psi + (\gamma - \gamma_N) e_r \right) = 0$$

for all $\zeta \in V$, with $\zeta(r, z) = 0$ for small r . If

$$\zeta = \eta^2(\psi - m) \quad \text{with } m \in \mathbb{R}, \eta \in C_0^\infty(\mathbb{R}^2)$$

is such a test function, we derive that

$$\int_{\Omega} \frac{\eta^2}{r^{n-2}} |\nabla \psi|^2 \leq C \int_{\Omega} \left(\eta^2 r^{n-2} + \frac{|\nabla \eta|^2}{r^{n-2}} (\psi - m)^2 \right).$$

In particular, if $x_0 = (r_0, z_0) \in \bar{\Omega}$ with $r_0 > \delta$ ($\delta > 0$, fixed) and if $r_0 - 2\rho \geq \delta$, let η be a standard cut-off function satisfying $\eta(x) = 1$ for $|x - x_0| \leq \rho$ and $\eta(x) = 0$ for $|x - x_0| \geq 2\rho$. In the three cases:

- (i) $B_{2\rho}(x_0) \subset \Omega$, $m = \int_{\Omega \cap B_{2\rho}(x_0) \setminus B_\rho(x_0)} \psi$;
- (ii) $r_0 = R$, $[z_0 - 2\rho, z_0 + 2\rho] \subset [0, 1]$, m as in (i);
- (iii) $z_0 = 0$ (or 1), $2\rho < 1$, $m = 0$ (or Q);

we can apply the above inequality. Using Poincaré's inequality for $\psi - m$ on $\Omega \cap B_{2\rho}(x_0) \setminus B_\rho(x_0)$ we obtain an estimate

$$\int_{\Omega \cap B_\rho(x_0)} |\nabla \psi|^2 \leq C_\delta \left(\rho^2 + \int_{\Omega \cap B_{2\rho}(x_0) \setminus B_\rho(x_0)} |\nabla \psi|^2 \right).$$

From this we deduce for given $\delta > 0$ (as above) and $\varepsilon > 0$

$$\int_{\Omega \cap B_\rho(x_0)} |\nabla \psi|^2 \leq C_{\delta, \varepsilon} \rho^{2-\varepsilon}$$

for all $x_0 = (r_0, x_0) \in \bar{\Omega}$ and $\rho > 0$ with $r_0 - 2\rho \geq \delta$. Then by the Morrey lemma, see [9], the Hölder continuity of ψ away from the axis and with any Hölder exponent follows.

For $n = 2$, the same procedure applies at the axis outside the well. To obtain the result for $n \geq 3$ we switch to the pressure formulation of the problem. In the proof of Lemma 2.1, the function ψ_0 has been defined by p_0 . Here we want to define the pressure p by the stream function ψ , which locally in Ω is a weak solution of

$$\nabla \cdot \left(\frac{1}{r^{n-2}} \nabla \psi + \gamma e_r \right) = 0,$$

where the vector field under the divergence is in $L^2_{loc}(\Omega; \mathbb{R}^2)$. Since Ω is simply connected, there exists (up to an additive constant) a unique function $p \in H^1_{loc}(\Omega)$ with

$$\partial_z p = - \left(\frac{1}{r^{n-2}} \partial_r \psi + \gamma \right), \quad \partial_r p = \frac{1}{r^{n-2}} \partial_z \psi.$$

Further, since $\partial_r \partial_z \psi = \partial_z \partial_r \psi$ in distributional sense, p is a weak solution of

$$\partial_r(r^{n-2} \partial_r p) + \partial_z(r^{n-2}(\partial_z p + \gamma)) = 0.$$

Now consider the corresponding quantities on the n -dimensional domain $\tilde{\Omega}$, e.g.

$$\tilde{p}(x_1, \dots, x_n) = p(r, x_n) \quad \text{with } r = \sqrt{x_1^2 + \dots + x_{n-1}^2}.$$

It follows that for $\tilde{\zeta} \in C_0^\infty(\tilde{\Omega})$, with $\tilde{\zeta}(x) = 0$ for small r ,

$$\int_{\tilde{\Omega}} \nabla \tilde{\zeta} \cdot (\nabla \tilde{p} + \tilde{\gamma} e_{x_n}) = \int_{\Omega} r^{n-2} \nabla \zeta \cdot (\nabla p + \gamma e_z) = 0,$$

where

$$\zeta(r, z) = \int \tilde{\zeta}(r\xi, z) d\mathcal{H}^{n-1}(\xi).$$

Moreover, since $\psi - \psi_0 \in V$, it follows from (2.5) that $r^{2-n} |\nabla \psi|^2 \in L^1(\Omega \setminus B_\varepsilon(W))$. This implies that $r^{n-2} |\nabla p|^2 \in L^1(\Omega \setminus B_\varepsilon(W))$; that is, $|\nabla \tilde{p}| \in L^2(\tilde{\Omega} \setminus \{r=0\} \setminus B_\varepsilon(W))$.

Since the axis $\{r=0\}$ is a removable singularity for $H^{1,2}$ -spaces, it follows that $\tilde{p} \in H^1_{loc}(\tilde{\Omega} \setminus W)$ and $\int_{\tilde{\Omega}} \nabla \tilde{\zeta} \cdot (\nabla \tilde{p} + \tilde{\gamma} e_{x_n}) = 0$ for all $\tilde{\zeta} \in C_0^\infty(\tilde{\Omega} \setminus W)$. We then can apply the above technique to obtain

$$\int_{B_\rho(x)} |\nabla \tilde{p}|^2 \leq C \rho^{n-\varepsilon}$$

locally in $\tilde{\Omega} \setminus W$. Covering $(n-2)$ -dimensional rings by balls this gives

$$\int_{\Omega \cap B_\rho(x_0)} r^{n-2} |\nabla p|^2 \leq C \left(1 + \left(\frac{r_0}{\rho} \right)^{n-2} \right) \rho^{n-\varepsilon}$$

for balls $B_\rho(x_0)$ away from the well and $x_0 = (r_0, z_0)$.

Since

$$r^{2-n} |\nabla \psi|^2 \leq 2r^{n-2} (|\nabla p|^2 + 1),$$

we obtain the estimate

$$\int_{\Omega \cap B_\rho(x_0)} \frac{1}{r^{n-2}} |\nabla \psi|^2 \leq C \rho^{2-\varepsilon}.$$

Again, the Morrey lemma implies the Hölder continuity, at the axis and away from the well. \square

THEOREM 3.6 ψ is Lipschitz continuous locally in $\Omega \cup \{(R, z); 0 < z < 1\}$.

Proof. We follow the proof of Lipschitz continuity in [3; see also 4: Theorem 3.8]. To include the boundary $\partial_N \Omega$ we reflect ψ by

$$\psi(r, z) := \psi(2R - r, z) \quad \text{for } R \leq r < 2R.$$

Setting

$$a(r, z) := \begin{cases} r^{2-n} & \text{for } r < R, \\ (2R - r)^{2-n} & \text{for } r > R, \end{cases} \quad \beta(r, z) := \begin{cases} \gamma(r, z) & \text{for } r < R \\ -\gamma(2R - r, z) & \text{for } r > R \end{cases}$$

we see that equation (★) in Section 2 becomes

$$\int_D \nabla \zeta \cdot (a \nabla \psi + \beta e_r) = \int_{\partial_N \Omega} \zeta 2\gamma_N \quad (3.1)$$

for test functions ζ with support in $D := \{(r, z); 0 < r < 2R, 0 < z < 1\}$. Note that a is locally Lipschitz continuous in D .

First we derive a monotonicity formula. Let

$$\varphi(\rho) := \varphi_1(\rho) \cdot \varphi_2(\rho), \quad \varphi_i(\rho) := \int_{B_\rho} a |\nabla w_i|^2,$$

where $B_\rho = B_\rho(x_0)$ with $\psi(x_0) = Q_s$, and $w_1 = \max(\psi - Q_s, 0)$, $w_2 = \min(\psi - Q_s, 0)$. We claim that

$$\varphi' \geq -2L\varphi,$$

where L is the local Lipschitz constant of a . To prove this replace ζ by ζw_i and obtain

$$\begin{aligned} \int_D \nabla(\zeta w_i) \cdot a \nabla w_i &= 2 \int_{\partial_N \Omega} \zeta w_i \gamma_N - \int_D \partial_r(\zeta w_i) \beta \\ &= c_i \{ 2 \int_{\partial_N \Omega} \zeta w_i - \int_{D \cap \Omega} \partial_r(\zeta w_i) + \int_{D \setminus \Omega} \partial_r(\zeta w_i) \} = 0, \end{aligned}$$

where $c_1 = 0$, $c_2 = 1$ and (★★) in Section 2 has been used. Letting $\xi \rightarrow \chi_{B_\rho}$ in an appropriate way, we derive that for almost all ρ

$$\int_{B_\rho} a |\nabla w_i|^2 = \int_{\partial B_\rho} a w_i \partial_\rho w_i.$$

Since

$$\varphi'(\rho) + \frac{4}{\rho} \varphi(\rho) = \sum_{i \neq j} \frac{\varphi_j(\rho)}{\rho^2} \int_{\partial B_\rho} a |\nabla w_i|^2,$$

we only have to consider the case $\varphi(\rho) > 0$. Then

$$\begin{aligned} \rho \frac{\varphi'(\rho)}{\varphi(\rho)} + 4 &= \rho \sum_i \frac{\int_{\partial B_\rho} a \left(|\partial_\rho w_i|^2 + \left| \frac{1}{\rho} \partial_\theta w_i \right|^2 \right)}{\int_{\partial B_\rho} a w_i \partial_\rho w_i} \\ &\geq 2 \sum_i \frac{\left(\int_{\partial B_\rho} a |\partial_\theta w_i|^2 \right)^{1/2}}{\left(\int_{\partial B_\rho} a |w_i|^2 \right)^{1/2}} \geq 2\sqrt{c_\rho} \sqrt{s_i}, \end{aligned}$$

where

$$c_\rho := \frac{\inf_{B_\rho} a}{\sup_{B_\rho} a} \quad \text{and} \quad s_i := \frac{\int_{\partial B_\rho} |\partial_\theta w_i|^2}{\int_{\partial B_\rho} |w_i|^2}.$$

Since (see [3]) $\sqrt{s_1} + \sqrt{s_2} \geq 2$, we obtain

$$\frac{\varphi'(\rho)}{\varphi(\rho)} \geq -\frac{4}{\rho}(\sqrt{c_\rho} - 1).$$

Since $c_\rho \geq 1 - L\rho$, the assertion follows.

Next we derive a mean value estimate. Let again $B_\rho = B_\rho(x_0)$ with $\psi(x_0) = Q_s$, G_x Green's function for the negative Laplacian with pole $x \in B_\rho$, and P_x the corresponding Poisson function. Then, setting $u = \psi - Q_s$,

$$u(x) - \int_{\partial B_\rho} P_x u = \int_{B_\rho} \nabla G_x \cdot \nabla \psi,$$

where the right-hand side is well defined by the L^2 -gradient estimate in the previous proof. Using identity (3.1) with $\zeta = G_x$, it becomes

$$= -\frac{1}{a(x)} \left\{ \int_{B_\rho} \nabla G_x \cdot (a - a(x)) \nabla \psi + \int_{B_\rho} \nabla G_x \cdot \beta e_r + \int_{B_\rho \cap \partial_N \Omega} G_x 2\gamma_N \right\}.$$

Therefore we obtain for $x \in B_{\rho/2}$

$$\begin{aligned} \left| u(x) - \int_{\partial B_\rho} P_x u \right| &\leq C \left\{ \int_{B_\rho} |\nabla \psi| + \int_{B_\rho} |\nabla G_x| + \int_{B_\rho \cap \partial_N \Omega} |G_x| \right\} \\ &\leq C\rho \left(\|\nabla \psi\|_{L^2(B_\rho)} + 1 \right) \\ &\leq C\rho. \end{aligned}$$

For $x = x_0$ this gives

$$\left| \int_{\partial B_\rho} u \right| \leq C\rho.$$

Together with the monotonicity formula it follows as in [ACF2: Lemma 5.2] that

$$\int_{\partial B_\rho} |u| \leq C\rho.$$

Then the above estimate for $x \in B_{\rho/2}$ implies

$$\|u\|_{L^\infty(B_{\rho/2})} \leq C\rho.$$

Finally, we use the fact that $\nabla \cdot a \nabla \psi = 0$ in $\Omega \cap \{\psi \neq Q_s\}$ with smooth coefficient a . Let $x \in \Omega \cap \{\psi \neq Q_s\}$ near the free boundary, $\rho := \text{dist}(x, \{\psi = Q_s\})$ and $x_0 \in \partial B_\rho(x) \cap \{\psi = Q_s\}$. Then by the elliptic $C^{1,\alpha}$ -estimate

$$|\nabla \psi(x)| \leq C \frac{1}{\rho} \int_{B_\rho(x)} |\psi - Q_s|,$$

where the interior estimate was used if $B_{\rho/2}(x) \subset \Omega$. Otherwise one has to apply the boundary estimate with homogeneous Neumann data. Since $B_\rho(x) \subset B_{\tilde{\rho}/2}(x_0)$ with $\tilde{\rho} = 4\rho$, we obtain by the above L^∞ -estimate

$$|\nabla \psi(x)| \leq C.$$

□

4. Free boundary

The continuity and z -monotonicity of the solution ψ in Section 3 imply that in Ω , the boundary of $\{\psi > Q_s\}$ is the graph in the z -direction of an upper semicontinuous function, similarly the boundary of $\{\psi < Q_s\}$ is the graph of a lower semicontinuous function. We prove that the two functions coincide, i.e. a mushy region does not occur.

This essentially follows from the following

NON-OSCILLATION LEMMA 4.1 *Suppose in Ω there are four vertical lines*

$$\ell_i := \{(r_i, z); z_1 \leq z \leq z_2\}, \quad i = 1, \dots, 4$$

with $z_1 < z_2$, $r_1 < r_2 < r_3 < r_4$, such that $\psi - Q_s$ has no zeros on these lines and changes sign on successive lines, for instance as in Fig. 9.

Then

$$z_2 - z_1 \leq \frac{2L}{r_1^{n-2}} (r_4 - r_1),$$

where L is the Lipschitz constant of ψ on the rectangle enclosing the four lines.

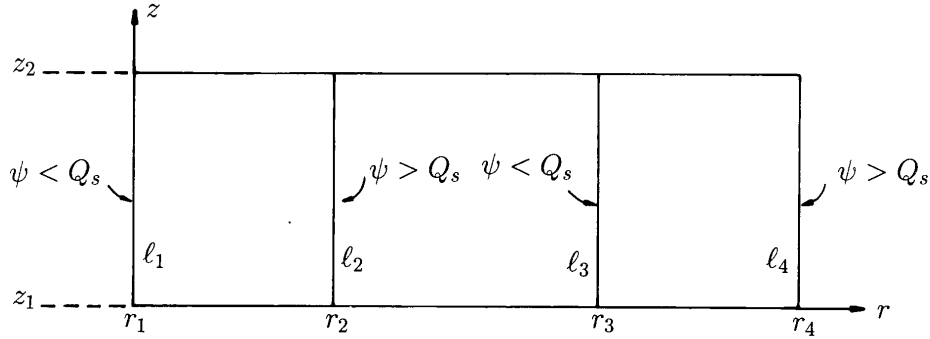

FIG. 9. Sign change of $\psi - Q_s$ on successive lines.

Proof. We use the following. In the open set $\{\psi \neq Q_s\}$, the stream function solves the analytic elliptic equation

$$\partial_r \left(\frac{1}{r^{n-2}} \partial_r \psi \right) + \partial_z \left(\frac{1}{r^{n-2}} \partial_z \psi \right) = 0.$$

It follows that at each point $(r, z) \in \Omega$ with $\psi(r, z) \neq Q_s$, either $\nabla \psi(r, z) \neq 0$ or that $\nabla \psi(r, z) = 0$ and the level set $\{\psi = \psi(r, z)\}$ near (r, z) consists of an even number of smooth lines:

either

or

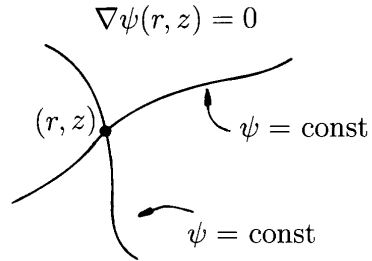
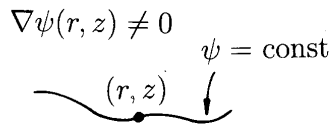

In particular, points with the latter property are isolated. By an arbitrary small perturbation of z_1, z_2 we can assume that

$$\nabla \psi(r, z) \neq 0 \quad \text{for } r_1 \leq r \leq r_4, \quad z = z_1 \text{ or } z_2.$$

For definiteness, let us assume that $\psi < Q_s$ on l_1 . Consider the rectangle

$$R_1 := [r_1, r_3] \times [z_1, z_2].$$

Choose ξ_1 with $r_1 < \xi_1 < r_3$ so that

$$\psi(\xi_1, z_1) = \sup_{r_1 \leq r \leq r_3} \psi(r, z_1) > Q_s.$$

Since $\partial_z \psi \geq 0$ by Lemma 3.4 and $\nabla \psi(\xi_1, z_1) \neq 0$ by the choice of z_1 , it follows that $\nabla \psi(\xi_1, z_1)$ points upwards, i.e. $\partial_z \psi(\xi_1, z_1) > 0$. We thus can construct in R_1 a curve $s \mapsto \sigma_1(s)$, with $\sigma_1(0) = (\xi_1, z_1)$, so that

$$\sigma_1'(s) = \frac{\nabla \psi(\sigma_1(s))}{|\nabla \psi(\sigma_1(s))|} \quad \text{whenever } \nabla \psi(\sigma_1(s)) \neq 0,$$

and so that σ_1 is Lipschitz continuous. By the properties of ψ on ∂R_1 it follows that the curve reaches a point $(\tilde{\xi}_1, z_2) = \sigma_1(s_1)$ on ∂R_1 , as in Fig. 10.

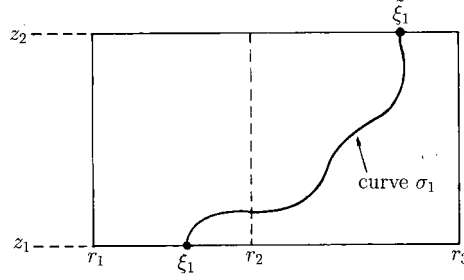

FIG. 10. Construction of the curve σ_1 in R_1 .

Similarly, let

$$R_2 := [r_2, r_4] \times [z_1, z_2]$$

and choose ξ_2 , with $\max(r_2, \tilde{\xi}_1) < \xi_2 < r_4$, so that

$$\psi(\xi_2, z_2) = \inf_{\max(r_2, \tilde{\xi}_1) \leq r \leq r_4} \psi(r, z_2) < Q_s.$$

As above, $\nabla \psi(\xi_2, z_2)$ points upwards, so that there exists a curve $s \mapsto \sigma_2(s)$ in R_2 , with $\sigma_2(0) = (\xi_2, z_2)$, so that

$$\sigma_2'(s) = -\frac{\nabla \psi(\sigma_2(s))}{|\nabla \psi(\sigma_2(s))|} \quad \text{whenever } \nabla \psi(\sigma_2(s)) \neq 0.$$

As before, this curve reaches a point $(\tilde{\xi}_2, z_1) = \sigma_2(s_2)$ on ∂R_2 .

Since $\psi > Q_s$ on σ_1 and $\psi < Q_s$ on σ_2 it follows that $\tilde{\xi}_2 > \xi_1$. Let R be the region bounded by σ_1 , σ_2 and the horizontal segments $\{(r, z_1) : \xi_1 \leq r \leq \tilde{\xi}_2\}$ and $\{(r, z_2) : \xi_1 \leq r \leq \tilde{\xi}_2\}$, see Fig. 11

The idea is now to integrate $\Delta \psi$ over R and to use on the one hand Gauss' theorem and on the other hand the differential equation. To make this precise, we have to use the weak equation for ψ with test function

$$\zeta(r, z) = \eta(z) d_\rho(r, z), \quad \rho > 0 \text{ small},$$

where

$$d_\rho(r, z) = \min \left(1, \frac{1}{\rho} \text{dist}((r, z), \partial R) \right),$$

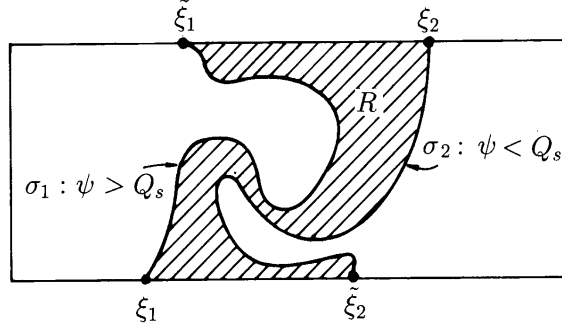
FIG. 11. Construction of the region R .

and where η is a cut-off function $\eta \in C_0^\infty([z_1, z_2])$ with $0 \leq \eta \leq 1$. Then

$$\begin{aligned} \int_R \frac{1}{r^{n-2}} \nabla \zeta \cdot \nabla \psi &= - \int_R \nabla \zeta \cdot (\gamma e_r) \\ &= - \int_R \eta \gamma \partial_r d_\rho. \end{aligned}$$

For small ρ we have $\partial_r d_\rho \neq 0$ only near σ_2 , where $\gamma = 1$, and near σ_1 , where $\gamma = 0$. Hence the right-hand side integral becomes

$$\begin{aligned} - \int_{z_1}^{z_2} \eta(z) \left(\int_{\{r; (r,z) \in R \cap B_\rho(\sigma_2)\}} \partial_r d_\rho(r, z) dr \right) dz \\ = \int_{z_1}^{z_2} \eta(z) dz. \end{aligned}$$

Thus

$$\int_{z_1}^{z_2} \eta(z) dz = \int_R \frac{1}{r^{n-2}} d_\rho \partial_z \eta \partial_z \psi + \int_R \frac{\eta}{r^{n-2}} \nabla d_\rho \cdot \nabla \psi.$$

The last integral tends to 0 as $\rho \rightarrow 0$, since $\nabla \psi$ is tangential on σ_1, σ_2 by construction of these

curves. Hence we obtain

$$\begin{aligned} \int_{z_1}^{z_2} \eta(z) \, dz &\leq \int_R \frac{1}{r^{n-2}} |\partial_z \eta| |\partial_z \psi| \\ &\leq \frac{L}{r_1^{n-2}} \int_R |\partial_z \eta| \leq \frac{L(r_4 - r_1)}{r_1^{n-2}} \int_{z_1}^{z_2} |\partial_z \eta(z)| \, dz. \end{aligned}$$

Now choosing η as in Fig. 12 and letting $\varepsilon \searrow 0$ we obtain the assertion. □

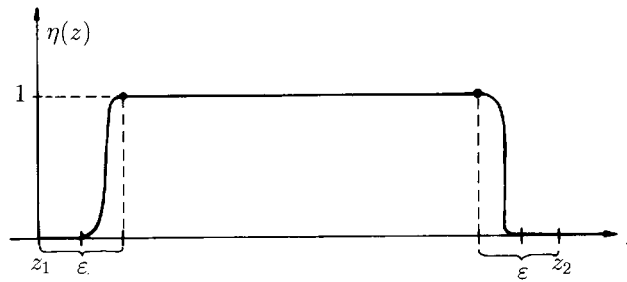

FIG. 12. Properties of the test function η .

Next we show

PROPOSITION 4.2 *A free boundary cannot contain isolated vertical segments: i.e. a situation as below cannot occur.*

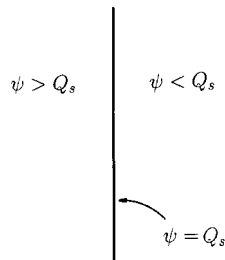

FIG. 13. Isolated vertical segment.

Proof. See also [4]. It follows that $\partial_z \gamma = 0$ in distributional sense in a neighbourhood U of the segment. For small $\delta > 0$, consider the function $v(r, z) := \psi(r, z + \delta) - \psi(r, z)$. Then $v \geq 0$ by

Proposition 3.4, $v = 0$ on the segment, and v is a continuous solution of $\nabla \cdot (r^{2-n} \nabla v) = 0$ in U . By elliptic regularity theory v is smooth, and therefore $v = 0$ by the strong maximum principle. We conclude that $\psi(r, z) = \varphi(r)$ in U with a continuous function φ different from Q_s away from the segment. This argument extends to small vertical strips, on the left of the segment reaching the top of Ω and on the right of the segment reaching the bottom of Ω . This yields a contradiction to the Dirichlet data. \square

Next we show that a mushy region (if it exists) increases to the left.

LEMMA 4.3 *Suppose there exist $r_0 \in]0, R[$ and $z_1, z_2 \in]0, 1[$, with $z_1 < z_2$, such that*

$$\psi(r_0, z) \begin{cases} > Q_s & \text{for } z_2 < z < 1 \\ = Q_s & \text{for } z_1 \leq z \leq z_2 \\ < Q_s & \text{for } 0 < z < z_1. \end{cases}$$

Then

$$\psi = Q_s \text{ in }]0, r_0] \times [z_1, z_2].$$

Proof. Consider two points $T = (r_0, z_T)$ and $B = (r_0, z_B)$ with $z_1 \leq z_B < z_T \leq z_2$, and two sequences $(x_n)_{n \in \mathbb{N}}$, $(\tilde{x}_n)_{n \in \mathbb{N}}$ with $x_n = (r_n, z_n)$, $r_n < r_0$, $x_n \rightarrow T$ as $n \rightarrow \infty$ and $\tilde{x}_n = (\tilde{r}_n, \tilde{z}_n)$, $\tilde{r}_n < r_0$, $\tilde{x}_n \rightarrow B$ as $n \rightarrow \infty$, see Fig. 14. Now assume that $\psi(x_n) < Q_s$ and $\psi(\tilde{x}_n) > Q_s$ for large n . \square

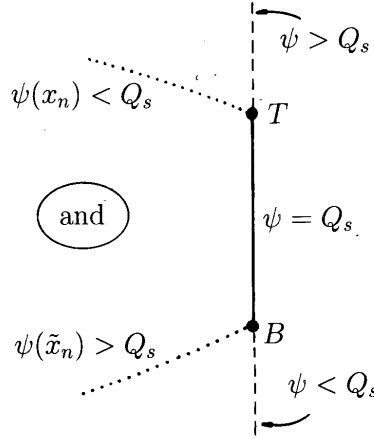

FIG. 14. Sequences $(x_n)_{n \in \mathbb{N}}$ and $(\tilde{x}_n)_{n \in \mathbb{N}}$.

Then in view of the non-oscillation result, these sequences cannot exist simultaneously. Therefore we have to deal with one of the following two cases.

Case 1. $\psi \geq Q_s$ in a left neighbourhood N of T .

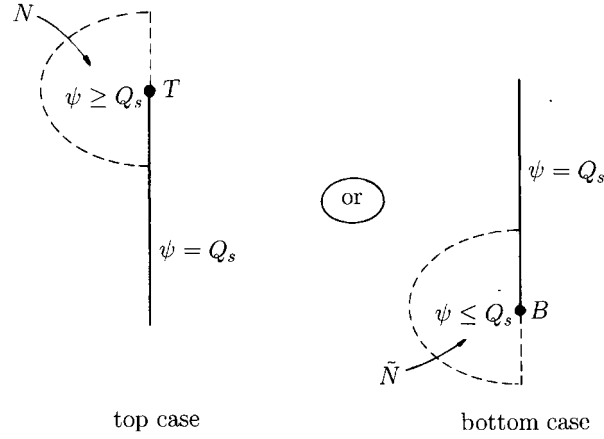

FIG. 15. Two possible cases.

Case 2. $\psi \leq Q_s$ in a left neighbourhood \tilde{N} of B .
 In the first case we assert

CLAIM 4.4 $\psi = Q_s$ in $L := N \cap]0, r_0] \times [z_B, z_T]$.

Proof. Suppose the assertion is not true. Then there exists a point $x \in L$, where $\psi(x) > Q_s$. The Hölder continuity of ψ implies the existence of a neighbourhood M where $\psi > Q_s$ and consequently $\gamma = 0$, see Fig. 16.

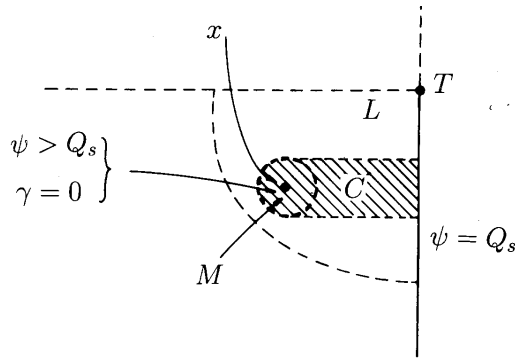

FIG. 16. Construction of sets.

Next, consider the set $C \subset L$ shown as the shaded region in Fig. 16. Since $\psi \geq Q_s$ in C we

have

$$\nabla \cdot (r^{2-n} \nabla \psi) \geq 0 \quad \text{and thus} \quad \partial_r \gamma \leq 0 \quad \text{in } C,$$

by the differential equation for ψ . Using $\gamma \geq 0$ in Ω and $\gamma = 0$ in M , we find $\gamma = 0$, $\nabla \cdot (r^{2-n} \nabla \psi) = 0$ and, by the strong maximum principle, $\psi > Q_s$ in C .

Next we choose points $P \neq \tilde{P}$ as in Fig. 17. By the non-oscillation result (argue as for cases 1, 2 above, but now from the right instead of the left) we have either $\psi \geq Q_s$ in a small horizontal strip to the right of the point P , or $\psi \leq Q_s$ in a small horizontal strip to the right of \tilde{P} .

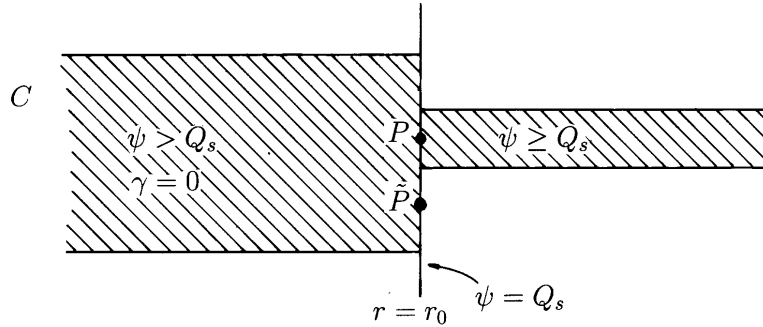

FIG. 17. Possible situation near P .

First consider $\psi \geq Q_s$ in a right neighbourhood of P . This implies again $\nabla \cdot (r^{2-n} \nabla \psi) \geq 0$ and $\partial_r \gamma \leq 0$ in the shaded area of Fig. 17. Since $\gamma = 0$ in C , we have $\gamma = 0$, $\nabla \cdot (r^{2-n} \nabla \psi) = 0$ and thus $\psi > Q_s$ in the shaded area. In particular, $\psi(P) > Q_s$ which gives a contradiction.

Finally, consider the case $\psi \leq Q_s$, $\psi \neq Q_s$, in every small right neighbourhood of \tilde{P} . If $x' = (r', z')$ is a point in such a neighbourhood with $\psi(x') < Q_s$ then, using similar arguments as before, $\psi < Q_s$ in the shaded region of Fig. 18. In particular, $\psi(r', z') < Q_s$ for $r > r'$. Since $\partial_z \psi \geq 0$, this implies $\psi < Q_s$ and $\gamma = 1$ in the region with upper left corner x' , see again Fig. 18.

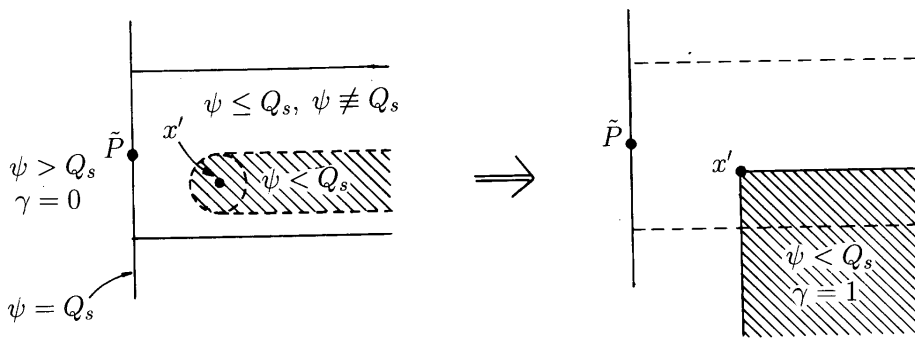
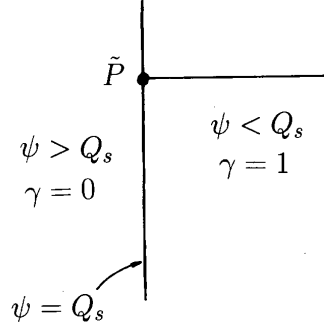

FIG. 18. Construction in a right neighbourhood.

By assumption, there exists a sequence $(x'_n = (r'_n, z'_n))_{n \in \mathbb{N}}$ with $x'_n \rightarrow \tilde{P}$ as $n \rightarrow \infty$, $r'_n > r_0$ and $\psi(x'_n) < Q_s$. As a consequence of Fig. 18, we therefore arrive at the following situation which is a contradiction to Proposition 4.2. This concludes the proof of the claim. \square



We continue with the proof of Lemma 4.3 using Claim 4.4. Assuming the top case of Fig. 15, we find $\psi = Q_s$ in L and, using $\partial_z \psi \geq 0$, $\psi \leq Q_s$ below L . Thus the top case implies the bottom case. Conversely, starting from the bottom case of Fig. 15, we find $\psi = Q_s$ in an upper left neighbourhood of B (repeat proof of Claim 4.4 with reversed signs). Using again the z -monotonicity of ψ we observe that the bottom case implies the top case. Therefore both cases are always true. Thus, by Claim 4.4, we are left with $\psi = Q_s$ in L , and similarly $\psi = Q_s$ in some left upper neighbourhood of B . This gives $\psi = Q_s$ to the left of the segment BT , which proves the lemma. \square

With these preparations we can prove

THEOREM 4.5 *The free boundary $\Omega \cap \{\psi = Q_s\}$ is the graph in the z -direction of a continuous function $g :]0, R[\rightarrow \mathbb{R}$. Moreover,*

$$h = \lim_{r \searrow 0} g(r) \quad \text{and} \quad u_s := \lim_{r \nearrow R} g(r) \in]0, 1[$$

exists.

Proof. From the continuity of ψ in Lemma 3.5 it follows that the free boundary stays away from the lower and upper boundary of Ω . Therefore, if the free boundary is not a continuous graph, a vertical segment as in Lemma 4.3 exists. However, then we conclude that $\psi = Q_s$ to the left, and therefore ψ cannot attain its boundary values on $\{r = 0\}$, which are either 0 or Q . Hence g exists and by the continuity of Theorem 3.5 we infer that $g(r) \rightarrow h$ as $r \searrow 0$. The last statement follows from the Non-Oscillation Lemma 4.1, taking into account that ψ is Lipschitz continuous up to the right boundary of Ω (Theorem 3.6). \square

REMARK 4.6 Theorem 4.5 implies that $\gamma = \chi_{\{z < g(r)\}}$ and $\gamma_N = \chi_{\{z < u_s\}}$. Moreover, we find for fixed $z \in]0, u_s[\cup]u_s, 1[$

$$\lim_{r \nearrow R} \gamma(r, z) = \gamma_N(z).$$

As a consequence, ψ satisfies the Neumann condition on $\partial_N \Omega$, away from the free boundary point.

5. Free boundary near well

It follows from Theorem 4.5 that the free boundary approaches W as a continuous curve. In this section we prove that the free boundary has a tangent at W and that it approaches W in a C^1 -sense.

We use polar coordinates.

$$r + i(z - h) = \rho e^{i\theta} \quad (5.1)$$

and consider a small neighbourhood

$$D_{\rho_0} := \{(r, z) \in \Omega; r^2 + (z - h)^2 < \rho_0^2\}.$$

The function ψ_* defined in Lemma 2.1 plays an important role in this section as well as in Section 6. It has the form

$$\psi_*(r, z) = \frac{Q}{2}(\varphi_*(r, z) + 1)$$

with

$$\varphi_*(r, z) = \tilde{\varphi}_*(\theta) = \begin{cases} \frac{2}{\pi}\theta & \text{for } n = 2, \\ \sin \theta & \text{for } n = 3, \end{cases}$$

implying that ψ_* is constant on rays starting at W . We therefore set

$$\tilde{\psi}_*(\theta) = \frac{Q}{2}(\tilde{\varphi}_*(\theta) + 1).$$

As ψ_0 , the function ψ_* satisfies

$$\partial_r(r^{2-n}\partial_r\psi_*) + \partial_z(r^{2-n}\partial_z\psi_*) = 0.$$

Hence, the local weak equation of ψ near W can be written as

$$\int_{D_{\rho_0}} \nabla \zeta \cdot (r^{2-n}\nabla(\psi - \psi_*) + \gamma e_r) = 0 \quad (5.2)$$

for all $\zeta \in C_0^\infty(D_{\rho_0})$.

DEFINITION 5.1 Define ω_* , with $-\frac{\pi}{2} < \omega_* < \frac{\pi}{2}$, by

$$\tilde{\psi}_*(\omega_*) = Q_s.$$

Thus $\psi_* = Q_s$ on the ray in the direction $e^{i\omega_*}$. We have

$$\tilde{\varphi}_*(\omega_*) = Q_{rel} := \frac{Q_s - Q_f}{Q_s + Q_f},$$

that is

$$\omega_* = \begin{cases} \frac{\pi}{2} Q_{rel} & \text{for } n = 2, \\ \arcsin Q_{rel} & \text{for } n = 3. \end{cases}$$

We shall need the following.

COMPARISON LEMMA 5.2 *Let $D \subset \Omega$ be open and connected, and let $\psi \in C_{loc}^{0,1}(D)$, $\gamma = 1 - H(\psi - Q_s)$ be a weak solution of*

$$\nabla \cdot (r^{2-n} \nabla \psi + \gamma e_r) = 0 \text{ in } D.$$

Further, let $\varphi \in C_{loc}^{0,1}(D)$, $\beta = 1 - H(\varphi - Q_s)$ be a smooth strict supersolution in the sense that

$$\nabla \cdot (r^{2-n} \nabla \varphi) = 0 \text{ in } D \cap \{\varphi \neq Q_s\},$$

$$D \cap \{\varphi = Q_s\} \text{ is a } C^2\text{-curve,}$$

$$[v \cdot (r^{2-n} \nabla \varphi + \beta e_r)] < 0 \text{ on } D \cap \partial\{\varphi < Q_s\}.$$

Then $\psi \leq \varphi$ in D implies $\psi < \varphi$ in D .

Note. The corresponding version for strict subsolutions also holds.

Proof. Let $x_0 = (r_0, z_0) \in D$ with $\psi(x_0) = \varphi(x_0)$. If $\psi(x_0) > Q_s$, then the strong maximum principle implies that $\psi = \varphi$ in the connected component of $\{\psi > Q_s\}$ containing x_0 . The same argument applies if $\psi(x_0) < Q_s$. Thus it remains to exclude the case that $\psi(x_0) = Q_s$. We consider the blow-up at x_0 . Since φ has a C^2 free boundary, the functions

$$\varphi_\delta(x) := \frac{1}{\delta} (\varphi(x_0 + \delta x) - \varphi(x_0))$$

converge to a piecewise linear function φ_0 , and $\{\varphi_0 = 0\}$ is a line through the origin. Moreover,

$$[v \cdot (r_0^{2-n} \nabla \varphi_0 + \beta_0 e_r)] < 0$$

on this line, where $\beta_0 = 1 - H(\varphi_0)$. Similarly

$$\psi_\delta \rightarrow \psi_0 \text{ weakly in } H_{loc}^{1,2}(\mathbb{R}^2),$$

$$\gamma_\delta \rightarrow \gamma_0 \text{ weak star in } L_{loc}^\infty(\mathbb{R}^2),$$

where ψ_0 is globally Lipschitz continuous with $\psi_0(0) = 0$ and

$$\nabla \cdot (r_0^{2-n} \nabla \psi_0 + \gamma_0 e_r) = 0 \text{ in } \mathbb{R}^2.$$

Furthermore, as in [4: Lemma 3.10],

$$\nabla \psi_\delta \rightarrow \nabla \psi_0 \text{ strongly in } L_{loc}^2(\mathbb{R}^2).$$

Following again [4: Lemma 3.10] and using the monotonicity formula derived in the proof of Theorem 3.6, we arrive at the following two cases:

- (i) ψ_0 is a piecewise linear two-phase solution. Then $\{\psi_0 = 0\} = \{\varphi_0 = 0\}$. Since $\psi_0 \leq \varphi_0$, ψ_0 satisfies the free boundary condition, and φ_0 the strict free boundary condition for a supersolution, we end up with a contradiction.

- (ii) ψ_0 has a sign. Since $\psi_0 \leq \varphi_0$ and $\{\varphi_0 < 0\}$ is non-empty, $\psi_0 \leq 0$ is a one-phase solution. Further, $\min(\varphi_0, 0)$ is a strict one-phase supersolution at its free boundary. Then we apply the bump argument [see 4: proof of Lemma 5.2] to derive a contradiction.

□

The next statement implies, that the free boundary has the unique tangent direction $e^{i\omega_*}$ at the well.

LEMMA 5.3 For small $\rho > 0$ there exist $\varepsilon_\rho > 0$ with $\varepsilon_\rho \rightarrow 0$ as $\rho \rightarrow 0$ so that

$$\psi_* - \varepsilon_\rho \leq \psi \leq \psi_* + \varepsilon_\rho \quad \text{in } D_\rho.$$

Proof. Let $\varepsilon \neq 0$ be small, $-\frac{\pi}{2} < \omega_\varepsilon < \frac{\pi}{2}$, and define

$$\tilde{\varphi}(\theta) := \begin{cases} \varepsilon + \frac{\tilde{\psi}_*(\theta)}{\tilde{\psi}_*(\omega_\varepsilon)} (Q_s - \varepsilon) & \text{for } -\frac{\pi}{2} \leq \theta \leq \omega_\varepsilon, \\ Q + \varepsilon - \frac{Q - \tilde{\psi}_*(\theta)}{Q - \tilde{\psi}_*(\omega_\varepsilon)} (Q + \varepsilon - Q_s) & \text{for } \omega_\varepsilon \leq \theta \leq \frac{\pi}{2}. \end{cases}$$

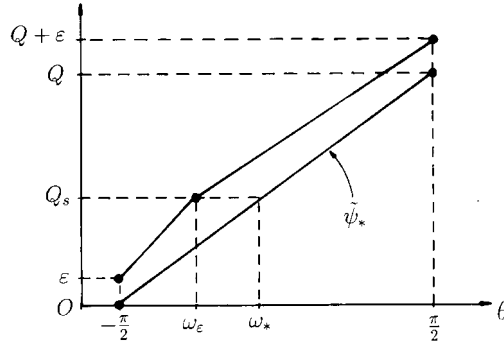

FIG. 19. $\tilde{\psi}$ for $n = 2$ and $\varepsilon > 0$.

Then

$$\tilde{\varphi}'(\omega_\varepsilon - 0) (\geq) \tilde{\varphi}'(\omega_\varepsilon + 0)$$

if and only if

$$\tilde{\psi}_*(\omega_\varepsilon) (\leq) \tilde{\psi}_*(\omega_*) - \varepsilon.$$

For small $|\varepsilon| > 0$ this is satisfied if $\omega_\varepsilon = \omega_* - a\varepsilon$, with $a > 1/\tilde{\psi}'_*(\omega_*) > 0$. We define

$$\varphi(r, z) := \tilde{\varphi}(\theta) \quad \text{with } \theta \text{ as in (5.1).}$$

Then on the free boundary of φ

$$\left[\nu \cdot r^{2-n} \nabla \varphi \right] (r, z) = r^{1-n} [\tilde{\varphi}'](\theta) \rightarrow -\infty (+\infty),$$

as $(r, z) \in \partial \{ \varphi < Q_s \} \rightarrow W$. It follows that φ is a smooth strict super-(sub-) solution in D_{ρ_ε} in the sense of Lemma 5.2, if ρ_ε is small enough. Moreover, if $|\varepsilon|$ is small enough, then $\partial_z \varphi > 0$.

In order to compare ψ with φ we use the fact that $\nabla(\psi - \psi_*) \in L^2(D_{\rho_0})$. Then by the Courant Lemma [C], there is a countable sequence $\rho \rightarrow 0$ with

$$\operatorname{osc}_{[-\frac{\pi}{2}, \frac{\pi}{2}]} (\tilde{\psi} - \tilde{\psi}_*)(\rho, \cdot) \rightarrow 0.$$

Since $\tilde{\psi}(\rho, -\frac{\pi}{2}) = 0 = \tilde{\psi}_*(-\frac{\pi}{2})$, we can choose $\rho < \rho_\varepsilon$ so that

$$|\psi - \psi_*| < |\varepsilon| \text{ on } \Omega \cap \partial D_\rho.$$

Then on this set $\psi \lesseqgtr \psi_* + \varepsilon \lesseqgtr \varphi$ and therefore

$$\psi \lesseqgtr \varphi \text{ on } \partial D_\rho \setminus W.$$

To apply Lemma 5.2, let $\varphi_\delta(r, z) := \varphi(r, z + \delta)$ for $\delta > 0$ (< 0). Obviously $\psi \lesseqgtr \varphi_\delta$ in \bar{D}_ρ for large $|\delta|$. Here we take the value Q for ψ at W and ε for φ_δ at $W - \delta e_z$ (0 for ψ and $Q + \varepsilon$ for φ_δ). Choose $|\delta|$ minimal with this property. Assume $|\delta| > 0$. Then $\psi \lesseqgtr \varphi_\delta$ in D_ρ by Lemma 5.2. Since $\partial_z \varphi > 0$ we still have $\psi \lesseqgtr \varphi_\delta$ on ∂D_ρ , which contradicts the minimality of $|\delta|$. Thus $|\delta| = 0$ and consequently

$$\psi \lesseqgtr \varphi \lesseqgtr \psi_* + C\varepsilon \text{ in } D_\rho.$$

□

For later use we introduce the scaling

$$\psi_\rho(x) := \psi(W + \rho(x - W)) \text{ for } x = (r, z) \text{ near } W,$$

the same for γ_ρ . Equation (5.2) then becomes

$$\int_{D_{\rho_0/\rho}} \nabla \zeta \cdot (r^{2-n} \nabla (\psi_\rho - \psi_*) + \rho^{n-1} \gamma_\rho e_r) = 0 \quad (5.3)$$

for $\zeta \in C_0^\infty(D_{\rho_0/\rho})$. Let $R > 0$ be a fixed large number and $\rho \ll \rho_0/R$.

From Lemma 5.3 we infer

$$|\psi_\rho - \psi_*| \leq \varepsilon_\rho \rightarrow 0 \text{ as } \rho \rightarrow 0 \text{ in } D_R, \quad (5.4)$$

$$\{ \psi_\rho = Q_s \} \cap D_R \subset \left\{ W + s e^{i\theta}; s > 0, |\theta - \omega_*| \leq \frac{2\varepsilon_\rho}{Q} \right\}. \quad (5.5)$$

PROPOSITION 5.4 *For $\sigma > 0$ consider the region*

$$G_R^\sigma := \{(r, z) = W + s e^{i\theta} \in \bar{D}_R; s \geq \sigma, |\theta - \omega_*| \geq \sigma\}.$$

Then for small ρ

$$|\nabla(\psi_\rho - \psi_*)| \leq C(\sigma, R)\varepsilon_\rho \text{ in } G_R^\sigma.$$

Proof. For small ρ we have $\nabla \cdot (r^{2-n} \nabla(\psi_\rho - \psi_*)) = 0$ in $G_{2R}^{\sigma/2}$. Then elliptic $C^{1,\alpha}$ -estimates together with (5.4) give the result. \square

The goal is to prove that $\nabla(\psi_\rho - \psi_*)$ is small up to the free boundary of ψ_ρ . We can prove at least the following:

LEMMA 5.5 *Let $R \gg 1$ and $\tau > 0$ be fixed. Then there exists $\kappa > 0$ with the following property for small ρ : for balls*

$$\hat{B} \subset D_R \cap \{\psi_\rho \leq Q_s\}, \quad \text{diam } \hat{B} \geq 2,$$

$$\hat{x} \in \partial \hat{B} \cap \{\psi_\rho = Q_s\}, \quad |\hat{x} - W| \geq 2,$$

we have

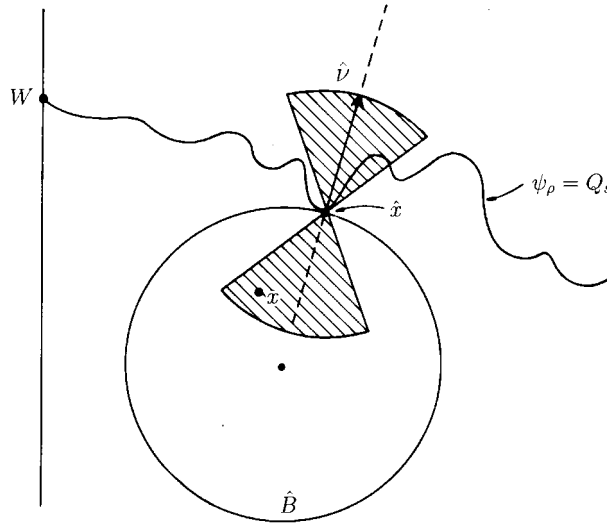

FIG. 20. Cone property.

$$\nabla \psi_\rho(\hat{x} + s e) \cdot e \geq \kappa$$

for $|s| \leq 1$ and $|e| = 1$ with $e \cdot \hat{v} \geq \tau$ (resp. $e \cdot (-\hat{v}) \geq \tau$), where \hat{v} is the outer normal to $\partial \hat{B}$ at \hat{x} .

Proof. It follows from (5.5) that for some $\sigma_0 > 0$ and for small ρ , for all \hat{B} as in the statement

$$\tilde{B} := \{x \in \hat{B}; (x - \hat{x}) \cdot \hat{v} \leq -1\} \subset G_R^{\sigma_0}.$$

Consider the case $\hat{B} \subset \{\psi_\rho < Q_s\}$. Then, by (5.4), for small ρ

$$\psi_\rho \leq \psi_* + \varepsilon_\rho \leq \tilde{\psi}_*(\omega_* - \sigma_0) + \varepsilon_\rho \leq Q_s - \delta_0 \quad \text{in } \tilde{B},$$

for some $\delta_0 > 0$. Since $\psi_\rho \leq Q_s$ and $\nabla \cdot (r^{2-n} \nabla \psi_\rho) = 0$ in \hat{B} , it follows from elliptic theory that

$$\psi_\rho(x) \leq Q_s - \kappa_0 \text{dist}(x, \partial \hat{B}), \quad x \in \hat{B}, \quad (5.6)$$

for some $\kappa_0 > 0$ being independent of ρ and \hat{B} .

Now let $\kappa > 0$. Assume the assertion fails. Thus, consider a sequence $\rho \rightarrow 0$ and $\hat{B}_\rho, \hat{x}_\rho, \hat{v}_\rho$ as in the statement and points

$$x_\rho = \hat{x}_\rho + s_\rho e_\rho, \quad |s_\rho| \leq 1, \quad (5.7)$$

$$|e_\rho| = 1, \quad e_\rho \cdot \hat{v}_\rho \geq \tau, \quad (5.8)$$

such that

$$\nabla \psi_\rho(x_\rho) \cdot e_\rho \leq \kappa. \quad (5.9)$$

The properties of \hat{B}_ρ together with (5.4), (5.5) imply that for a subsequence $\rho \rightarrow 0$

$$\hat{x}_\rho \rightarrow x_* = (r_*, z_*) = s_* e^{i\omega_*} \quad \text{with } s_* > 0, \quad (5.10)$$

$$\hat{v}_\rho \rightarrow v_* = i e^{i\omega_*}. \quad (5.11)$$

We claim that $\delta := |x_\rho - \hat{x}_\rho| \rightarrow 0$ as $\rho \rightarrow 0$. If not, it follows from (5.11), (5.8) and (5.5) that for a subsequence $\rho \rightarrow 0$, $x_\rho \in G_R^\sigma$ for some $\sigma > 0$. Then Proposition 5.4 implies, if $s_\rho \rightarrow s$ and $e_\rho \rightarrow e$ as $\rho \rightarrow 0$,

$$\begin{aligned} \nabla \psi_\rho(x_\rho) \cdot e_\rho &\geq \nabla \psi_*(x_\rho) \cdot e_\rho - C(\sigma, R)\varepsilon_\rho \\ &\rightarrow \nabla \psi_*(x_* + se) \cdot e. \end{aligned}$$

Since $\nabla \psi_*(x_*)$ is proportional to v_* , the infimum κ_1 for all such values of s and e with $|s| \leq 1$, $|e| = 1$, $e \cdot v_* \geq \tau$ is positive. Thus we derive a contradiction if $\kappa < \kappa_1$.

We first consider the case $x_\rho \in \hat{B}_\rho$, that is $s_\rho < 0$. We perform the blow-up with respect to the distances $\delta = |x_\rho - \hat{x}_\rho| = |s_\rho|$, that is we consider

$$\varphi_\delta(x) := \frac{1}{\delta} \left((\psi_\rho - \psi_*)(\hat{x}_\rho + \delta x) - (\psi_\rho - \psi_*)(\hat{x}_\rho) \right).$$

The regularity results obtained in Theorems 3.5 and 3.6 apply in a neighbourhood of x_* , uniformly in ρ , to the solutions ψ_ρ of (5.3). Therefore the functions φ_δ are Lipschitz continuous in any bounded domain, uniformly in δ . We conclude from (5.3) (as in the proof of Lemma 5.2) that $\varphi_\delta \rightarrow \varphi$ in $H_{loc}^{1,2}(\mathbb{R}^2)$ for a subsequence $\delta \rightarrow 0$, and that $\nabla \cdot (r_*^{2-n} \nabla \varphi) = 0$; that is, φ is harmonic. Moreover, φ is globally Lipschitz continuous and $\varphi(0) = 0$. Then it follows from Liouville's theorem that φ is linear; that is,

$$\varphi(x) = a \cdot x \quad \text{with } a \in \mathbb{R}^2. \quad (5.12)$$

For points $\hat{x}_\rho + \delta x \in \hat{B}_\rho$ we have, using (5.6),

$$\begin{aligned} \varphi_\delta(x) &\leq -\kappa_0 \text{dist}(\hat{x}_\rho + \delta x, \partial \hat{B}_\rho) \\ &\quad - \frac{1}{\delta} (\psi_*(\hat{x}_\rho + \delta x) - \psi_*(\hat{x}_\rho)) \end{aligned}$$

which, as $\rho \rightarrow 0$, results in lower case,

$$\varphi(x) \leq \kappa_0 x \cdot \nu_* - \nabla \psi_*(x_*) \cdot x \text{ for } x \cdot \nu_* < 0.$$

Since $\nabla \psi_*(x_*) = \beta \nu_*$ for some $\beta > 0$, we see that (5.9) implies $a = \alpha \nu_*$ with

$$\alpha \geq \kappa_0 - \beta.$$

Next we consider a subsequence for which

$$\frac{1}{\delta}(x_\rho - \hat{x}_\rho) = -e_\rho \rightarrow -e$$

with $e \cdot \nu_* \geq \tau > 0$ and we use (5.9). By (5.5), the free boundary corresponding to φ_δ converges to $\{x \cdot \nu_* = 0\}$. It follows from elliptic theory that $\varphi_\delta \rightarrow \varphi$ smoothly near $-e$. In particular, $\nabla \varphi_\delta(-e_\rho) \rightarrow \nabla \varphi(-e) = \alpha \nu_*$. Using assumption (5.9) we obtain

$$\begin{aligned} \nabla \varphi_\delta(-e_\rho) \cdot e_\rho &= \nabla(\psi_\rho - \psi_*)(x_\rho) \cdot e_\rho \\ &\leq \kappa - \nabla \psi_*(x_\rho) \cdot e_\rho \\ &\rightarrow \kappa - \beta \nu_* \cdot e \end{aligned}$$

and find

$$\kappa \geq (\alpha + \beta) \nu_* \cdot e \geq \tau(\alpha + \beta) \geq \tau \kappa_0,$$

a contradiction if $\kappa < \tau \kappa_0$.

Next we consider the case $s_\rho > 0$, where we assume that $\psi_\rho(x_\rho) \neq Q_s$. Again consider the blow-up with respect to $\delta = |x_\rho - \hat{x}_\rho| = s_\rho$. As before, $\varphi(x) = \alpha x \cdot \nu_*$ with $\alpha \geq \kappa_0 - \beta$. Let $\varepsilon > 0$. Then for $x \cdot \nu_* \geq \varepsilon$ we have

$$\begin{aligned} \frac{1}{\delta}(\psi_\rho(\hat{x}_\rho + \delta x) - Q_s) &= \varphi_\delta(x) + \frac{1}{\delta}(\psi_*(\hat{x}_\rho + \delta x) - \psi_*(\hat{x}_\rho)) \\ &\rightarrow (\alpha + \beta)x \cdot \nu_* \geq \kappa_0 \cdot \varepsilon > 0, \end{aligned}$$

locally uniformly in x . Choosing $\varepsilon < e \cdot \nu_*$ this says that the free boundary corresponding to φ_δ stays away from e , in particular $\psi_\rho(x_\rho) > Q_s$ for small ρ . We then derive a contradiction as before. Note that *a posteriori* this proves that $\psi_\rho(\hat{x}_\rho + s e_\rho) > Q_s$ for all $0 < s \leq 1$. \square

We are now in a position to prove the following.

THEOREM 5.6 *Let e be any direction different from $\pm e^{i\omega_*}$. Then for small ρ the free boundary in $\Omega \cap B_\rho(W)$ is a graph in direction e .*

Proof. Consider the situation for the scaled functions ψ_ρ . Choose two balls \hat{B}_1, \hat{B}_2 as in Lemma 5.5 and $\hat{W} = (0, \hat{h}) \neq W$, so that a region G as in Fig. 21 is well defined. For definiteness we assume that $\hat{B}_1, \hat{B}_2 \subset \{\psi_\rho < Q_s\}$ and that $\hat{h} < h$.

Note, see the previous proof, that $\hat{\nu}_1, \hat{\nu}_2$ are close to $i e^{i\omega_*}$ if ρ is small.

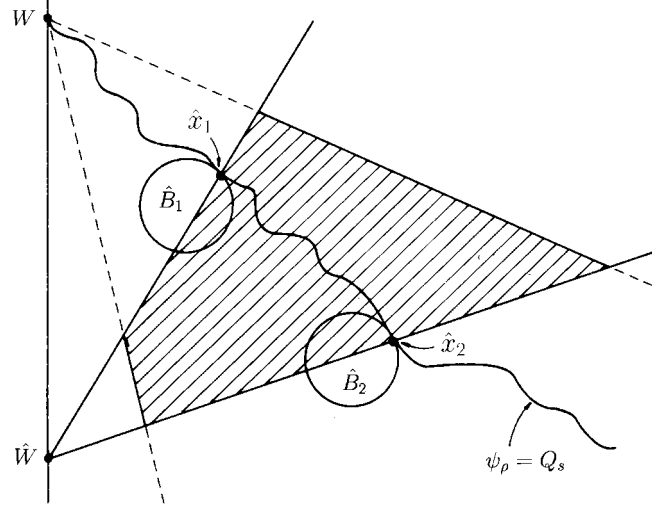

FIG. 21. Shaded region is G .

The following is a consequence of (5.4), (5.5) and Lemma 5.5. Consider a ray starting at \hat{W} . For rays contributing to ∂G , the function ψ_ρ is strictly increasing on ∂G . For rays cutting ∂G , the function ψ_ρ attains its minimum at the first cutting point and its maximum at the second cutting point. Now let $\lambda < 1$, near 1, and define

$$\psi_{\rho\lambda}(x) := Q_s + \frac{1}{\lambda^{n-1}}(\psi_\rho(\hat{W} + \lambda(x - \hat{W})) - Q_s),$$

$$G_\lambda := \{x; \hat{W} + \lambda(x - \hat{W}) \in G\}.$$

Then $\psi_{\rho\lambda}$ is a weak solution in G_λ . Below we show that

$$\psi_{\rho\lambda} < \psi_\rho \text{ on } \partial(G_\lambda \cap G). \tag{5.13}$$

If ψ^ε denotes the approximation of ψ from Section 3, then also $\psi_{\rho\lambda}^\varepsilon < \psi_\rho^\varepsilon$ on $\partial(G_\lambda \cap G)$ for small ε . As in Proposition 3.2, it then follows that $\psi_{\rho\lambda}^\varepsilon \leq \psi_\rho^\varepsilon$ in $G_\lambda \cap G$ resulting in $\psi_{\rho\lambda} \leq \psi_\rho$ in $G_\lambda \cap G$. As a consequence, ψ_ρ is monotonically increasing in G along rays starting at \hat{W} . Since we can vary \hat{B}_1 , \hat{B}_2 and \hat{W} the assertion follows.

It remains to prove (5.13) for λ near 1, provided the geometry of G is chosen appropriately. Consider the part

$$S = \{x = \hat{W} + se; \quad s_1 \leq s \leq s_2\},$$

of one of the above rays intersecting \bar{G} . It follows from (5.4), (5.5) and Lemma 5.5 that for small ρ

$$\nabla \psi_\delta(x) \cdot e \geq \kappa$$

for all $x \in S$ if $S \subset \partial G$, or for x near $\hat{W} + s_1 e$ and $\hat{W} + s_2 e$ otherwise. Note that $\kappa > 0$ is independent of the domains G that were chosen. It follows that for all points $x = \hat{W} + se$ under consideration and all $\lambda < 1$, near 1,

$$\psi_\rho(\hat{W} + se) - \psi_\rho(W + \lambda se) \geq \kappa(1 - \lambda)s.$$

Thus with

$$\xi := \psi_\rho(\hat{W} + se),$$

$$\begin{aligned} \psi_{\rho\lambda}(\hat{W} + se) - \psi_\rho(\hat{W} + se) &\leq Q_s - \xi + \frac{1}{\lambda^{n-1}}(\xi - \kappa(1 - \lambda)s - Q_s) \\ &= \frac{1 - \lambda}{\lambda^{n-1}} \left((\xi - Q_s) \frac{1 - \lambda^{n-1}}{1 - \lambda} - \kappa s \right) \\ &\leq \frac{1 - \lambda}{\lambda^{n-1}} (2L(s_2 - s_1) - \kappa s_1), \end{aligned}$$

where L is the Lipschitz constant of ψ in a suitable domain. Then it follows from (5.5) and Proposition 5.4 that for small ρ we can choose in the definition of G the two rays starting at W so that they enclose an angle of magnitude $C\varepsilon_\rho$. Finally, we choose G so that $s_2 - s_1 \leq C\varepsilon_\rho$ and $s_1 \geq c > 0$. This proves (5.13) for small ρ . \square

6. Asymptotic behaviour near the well

In Section 5 we have proved that the free boundary has a tangent $e^{i\omega_*}$ at W . Now we study how the free boundary approaches this tangent direction. In the analysis we use the standard conformal transformation

$$r + i(z - h) = e^{s+i\theta}, \quad \rho = e^s. \quad (6.1)$$

Then the neighbourhood $D := D_{\rho_0}$ in Section 5 becomes

$$\tilde{D} = \{(s, \theta); -\frac{\pi}{2} < \theta < \frac{\pi}{2}, -\infty < s < s_0\}, \quad \text{with } s_0 = \log \rho_0.$$

We denote the transformed functions by a superscript, for instance, $\tilde{\psi}(s, \theta) = \psi(r, z)$ with arguments related by (6.1).

We recall the local weak equation of ψ near W :

$$\int_D \nabla \zeta \cdot \left(\frac{1}{r^{n-2}} \nabla(\psi - \psi_*) + \gamma e_r \right) dr dz = 0 \quad (6.2)$$

for all $\zeta \in C_0^\infty(D)$. Since

$$\nabla \zeta = \frac{1}{r^2 + z^2} \begin{bmatrix} r & -z \\ z & -r \end{bmatrix} \nabla \tilde{\zeta},$$

the transformed weak equation becomes

$$\int_{\tilde{D}} \nabla \tilde{\zeta} \cdot \left(\frac{1}{r^{n-2}} \nabla(\tilde{\psi} - \tilde{\psi}_*) + \tilde{\gamma} \begin{bmatrix} r \\ -z \end{bmatrix} \right) ds d\theta = 0 \quad (6.3)$$

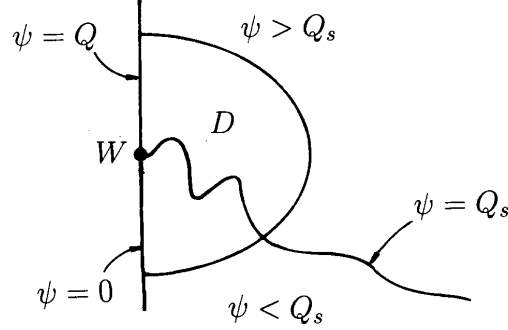

FIG. 22. Free boundary approaching the well.

for all $\tilde{\zeta} \in C_0^\infty(\tilde{D})$, where $r = e^s \cos \theta$ and $z = e^s \sin \theta$.

To demonstrate the behaviour near the well we apply the general method of separation of variables by giving an eigenfunction expansion in the θ -direction and by reducing (6.3) to ordinary differential equations for the coefficients in the s -variable. We first consider

LEMMA 6.1 *The eigenvalue problem, with $m = n - 2$ and $n = 2$ or 3 ,*

$$\begin{cases} \partial_\theta \left(\frac{1}{\cos^m \theta} \partial_\theta u \right) + \frac{1}{\cos^m \theta} \lambda u = 0 & \text{for } -\frac{\pi}{2} < \theta < \frac{\pi}{2}, \\ u \left(-\frac{\pi}{2} \right) = 0, \quad u \left(\frac{\pi}{2} \right) = 0, \end{cases}$$

has the following eigenfunctions e_k and eigenvalues λ_k for $k \geq 1$: for $m = 0$

$$e_k(\theta) = \sqrt{\frac{2}{\pi}} \sin \left(k \left(\theta + \frac{\pi}{2} \right) \right), \quad \lambda_k = k^2,$$

and for $m = 1$

$$e_k(\theta) = \sqrt{\frac{\lambda_k(2k+1)}{2}} \frac{1}{2^k k!} \left(\partial_t^{k-1} (t^2 - 1)^k \right) \Big|_t = \sin \theta, \quad \lambda_k = k(k+1).$$

These functions form an orthonormal basis of the weighted L^2 -space with inner product

$$\langle u, v \rangle := \int_{-\pi/2}^{\pi/2} \frac{u(\theta)v(\theta)}{\cos^m(\theta)} d\theta.$$

Proof. We only prove the case $m = 1$. Consider the transformation $t = \sin \theta$. Then the equation for $\tilde{u}(t) := u(\theta)$ is

$$(1 - t^2) \partial_t^2 \tilde{u} + \lambda \tilde{u} = 0, \quad (6.4)$$

and this gives for $\tilde{v} := \partial_t \tilde{u}$

$$\partial_t((1-t^2)\partial_t \tilde{v}) + \lambda \tilde{v} = 0.$$

Solutions (\tilde{v}, λ) are given by the Legendre polynomials

$$P_k(t) := \frac{1}{2^k k!} \partial_t^k (t^2 - 1)^k, \quad \lambda_k = k(k+1),$$

normalized so that $P_k(\pm 1) = (\pm 1)^k$. Moreover,

$$\int_{-1}^1 P_k(t) P_\ell(t) dt = \frac{2}{2k+1} \delta_{k,\ell}.$$

Then for $k \geq 1$, the functions

$$\tilde{E}_k(t) := \int_{-1}^t P_k(s) ds = \frac{1}{2^k k!} \partial_t^{k-1} (t^2 - 1)^k$$

vanish for $t = \pm 1$. Set $E_k(\theta) := \tilde{E}_k(\sin \theta)$. Using (6.4) for (\tilde{E}_k, λ_k) we see that

$$\begin{aligned} \langle E_k, E_\ell \rangle &= \int_{-1}^1 \frac{\tilde{E}_k(t) \tilde{E}_\ell(t)}{1-t^2} dt = -\frac{1}{\lambda_k} \int_{-1}^1 \tilde{E}_k''(t) \tilde{E}_\ell(t) dt \\ &= \frac{1}{\lambda_k} \int_{-1}^1 P_k(t) P_\ell(t) dt = \frac{2}{\lambda_k(2k+1)} \delta_{k,\ell}. \end{aligned}$$

Therefore define $e_k := \sqrt{\frac{\lambda_k(2k+1)}{2}} E_k$. The rest of the result then follows from spectral theory. \square

In addition we need the following estimates.

PROPOSITION 6.2 *There exists a constant C so that for all $k \geq 1$ and for all $|\theta| \leq \frac{\pi}{2}$*

$$\begin{aligned} |e_k(\theta)| &\leq C, \\ |e_k'(\theta)| &\leq C k^{1+\frac{m}{2}}. \end{aligned} \tag{6.6}$$

Proof. Again we only consider $m = 1$. We use the representation

$$P_k(\cos \vartheta) = \sum_{i=0}^k b_i b_{k-i} \cos((k-2i)\vartheta)$$

where

$$b_k := \prod_{1 \leq i \leq k} \left(1 - \frac{1}{2i}\right) = \frac{1 \cdot 3 \cdots (2k-1)}{2 \cdot 4 \cdots (2k)},$$

which implies that for $|t| \leq 1$, setting $t = \cos \vartheta$,

$$|P_k(t)| \leq \sum_{i=0}^k b_i b_{k-i} = P_k(\cos 0) = 1,$$

see [10: p93, 290]. It follows, again with $t = \cos \vartheta$, $0 \leq \vartheta \leq \pi$, that

$$\begin{aligned} \tilde{E}_k(t) &= \int_{\vartheta}^{\pi} P_k(\cos \vartheta) \sin \vartheta \, d\vartheta \\ &= \sum_{i=0}^k \frac{b_i b_{k-i}}{2} \int_{\vartheta}^{\pi} \{\sin((k+1-2i)\vartheta) - \sin((k-1-2i)\vartheta)\} \, d\vartheta. \end{aligned}$$

With

$$a_j(\vartheta) := j \int_{\vartheta}^{\pi} \sin(j\vartheta) \, d\vartheta = \cos(j\vartheta) - \cos(j\pi)$$

this gives

$$\tilde{E}_k(t) = \sum_{\substack{0 \leq i \leq k \\ 2i \neq k+1}} \frac{b_i b_{k-i}}{2(k+1-2i)} a_{k+1-2i}(\vartheta) - \sum_{\substack{1 \leq i \leq k+1 \\ 2i \neq k+1}} \frac{b_{i-1} b_{k+1-i}}{2(k+1-2i)} a_{k+1-2i}(\vartheta).$$

For $1 \leq i \leq k$, the expression

$$\frac{b_i b_{k-i} - b_{i-1} b_{k+1-i}}{k+1-2i}$$

does not change if we replace i by $k+1-i$, and it equals

$$\frac{b_{i-1} b_{k-i}}{k+1-2i} \left(\left(1 - \frac{1}{2i}\right) - \left(1 - \frac{1}{2(k+1-i)}\right) \right) = -\frac{b_{i-1} b_{k-i}}{2i(k+1-i)}.$$

Further, $a_j = a_{-j}$, so that

$$\tilde{E}_k(t) = \frac{b_0 b_k}{k+1} a_{k+1}(\vartheta) - \sum_{1 \leq i < \frac{k+1}{2}} \frac{b_{i-1} b_{k-i}}{2i(k+1-i)} a_{k+1-2i}(\vartheta).$$

Now, $|a_j(\vartheta)| \leq 2$ and $b_k \leq (k+1)^{-1/2}$ since

$$\log b_k = \sum_{i=1}^k \log \left(1 - \frac{1}{2i}\right) \leq -\frac{1}{2} \sum_{i=1}^k \frac{1}{i} \leq -\frac{1}{2} \log(k+1).$$

This implies the estimate

$$\begin{aligned} |\tilde{E}_k(t)| &\leq 2(k+1)^{-3/2} + \sum_{1 \leq i < \frac{k+1}{2}} i^{-3/2} (k+1-i)^{-3/2} \\ &\leq 2(k+1)^{-3/2} (1 + \sqrt{2} \sum_{i=1}^{\infty} i^{-3/2}), \end{aligned}$$

which proves (6.5). Since

$$E'_k(\theta) = P_k(\sin \theta) \cos \theta,$$

and $|P_k(\sin \theta)| \leq 1$, we obtain (6.6). \square

We note that estimate (6.6) might not be optimal, but it is sufficient to prove the desired convergence of the free boundary. In order to start the procedure, we need the following initial information about the free boundary near the well.

THEOREM 6.3 *For small enough ρ_0 there exists a continuous function $s \mapsto \omega(s) \in \left] -\frac{\pi}{2}, \frac{\pi}{2} \right[$ so that*

1. $\tilde{\psi}(s, \theta) < Q_s$, for $-\frac{\pi}{2} \leq \theta < \omega(s)$,
 $\tilde{\psi}(s, \theta) > Q_s$, for $\omega(s) < \theta \leq \frac{\pi}{2}$.
2. $\omega(s) \rightarrow \omega_*$ as $s \searrow -\infty$,
 where ω_* is defined in 5.1.

Proof. Follows from Lemma 5.3 and Theorem 5.6. \square

Next we define the coefficients in the eigenfunction expansion. For convenience we retain the notation $m = n - 2$.

DEFINITION 6.4 For any $s < s_0$ and $k \geq 1$, set

$$\begin{aligned} \psi_k(s) &:= \int_{-\pi/2}^{\pi/2} \frac{e_k(\theta)}{\cos^m \theta} (\tilde{\psi}(s, \theta) - \tilde{\psi}_*(\theta)) \, d\theta = \langle \tilde{\psi}(s, \cdot) - \tilde{\psi}_*, e_k \rangle, \\ c_k(s) &:= \int_{-\pi/2}^{\pi/2} e_k(\theta) \tilde{\gamma}(s, \theta) \cos \theta \, d\theta = \int_{-\pi/2}^{\omega(s)} e_k(\theta) \cos \theta \, d\theta, \\ s_k(s) &:= \int_{-\pi/2}^{\pi/2} e'_k(\theta) \tilde{\gamma}(s, \theta) \sin \theta \, d\theta = \int_{-\pi/2}^{\omega(s)} e'_k(\theta) \sin \theta \, d\theta. \end{aligned}$$

We have the identity

$$c_k(s) + s_k(s) = e_k(\omega(s)) \sin \omega(s) \quad \text{for all } s < s_0 \text{ and } k \geq 1. \quad (6.7)$$

PROPOSITION 6.5 *There exists a sequence $(s_j)_{j \in \mathbb{N}}$, with $s_j \rightarrow \infty$ as $j \rightarrow \infty$, so that for all j and for all $k \geq 1$*

$$|\psi_k(s_j)|^2 + |\psi'_k(s_j)|^2 \leq e^m s_j.$$

Proof. By the normalization of e_k we have

$$|\psi_k(s)|^2 \leq \int_{-\pi/2}^{\pi/2} \frac{|\tilde{\psi} - \tilde{\psi}_*(s, \theta)|^2}{\cos^m \theta} d\theta.$$

Since $(\tilde{\psi} - \tilde{\psi}_0)\left(s, -\frac{\pi}{2}\right) = 0$ we have

$$\begin{aligned} \int_{-\pi/2}^0 \frac{|\tilde{\psi} - \tilde{\psi}_*(s, \theta)|^2}{\cos^m \theta} d\theta &\leq \int_{-\pi/2}^0 \frac{\theta + \frac{\pi}{2}}{\cos^m \theta} \int_{-\pi/2}^0 |\partial_\theta(\tilde{\psi} - \tilde{\psi}_*)(s, \tilde{\theta})|^2 d\tilde{\theta} d\theta \\ &\leq C \int_{-\pi/2}^{\pi/2} |\partial_\theta(\tilde{\psi} - \tilde{\psi}_*)(s, \theta)|^2 d\theta. \end{aligned}$$

Similarly we argue for the integral over $[0, \pi/2]$. Moreover,

$$|\psi'_k(s)|^2 \leq \int_{-\pi/2}^{\pi/2} \frac{|\partial_s(\tilde{\psi} - \tilde{\psi}_*)(s, \theta)|^2}{\cos^m \theta} d\theta,$$

so that

$$|\psi_k(s)|^2 + |\psi'_k(s)|^2 \leq C \int_{-\pi/2}^{\pi/2} \frac{|\nabla(\tilde{\psi} - \tilde{\psi}_*)(s, \theta)|^2}{\cos^m \theta} d\theta.$$

The smoothness of the boundary data of the difference $\psi - \psi_*$ implies $|\nabla(\psi - \psi_*)|^2/r^m \in L^1(\Omega)$. Consequently,

$$\begin{aligned} \infty &> \int_D \frac{|\nabla(\psi - \psi_*)|^2}{r^m} dr dz = \int_{\tilde{D}} \frac{|\nabla(\tilde{\psi} - \tilde{\psi}_*)|^2}{e^{ms} \cos^m \theta} ds d\theta \\ &\geq \frac{1}{C} \int_{-\infty}^{s_0} e^{-ms} \sup_{k \geq 1} (|\psi_k(s)|^2 + |\psi'_k(s)|^2) ds. \end{aligned}$$

□

From this the assertion follows.

PROPOSITION 6.6 *There exists a constant C so that for all $s < s_0$ and all $k \geq 1$*

$$|s_k(s) - s_k(-\infty)| \leq C, \quad (6.8)$$

$$|s_1(s) - s_1(-\infty)| \leq C|\omega(s) - \omega_*| \quad (6.9)$$

$$|c_k(s) - c_k(-\infty)| \leq C \min\left(\omega(s) - \omega_*, k^{\frac{m}{2}-1}\right). \quad (6.10)$$

Proof. Using identity (6.7) and property (6.5) we see that (6.8) follows from (6.10). Further, (6.9) is obvious since e'_1 is bounded, see (6.6). Also, from property (6.5),

$$|c_k(s) - c_k(-\infty)| \leq C|\omega(s) - \omega_*|,$$

therefore it remains to show that for all $-\frac{\pi}{2} \leq \theta_- < \theta_+ \leq \frac{\pi}{2}$ and for all $k \geq 1$

$$\left| \int_{\theta_-}^{\theta_+} e_k(\theta) \cos \theta \, d\theta \right| \leq C k^{\frac{m}{2}-1}.$$

Using the differential equation for e_k we obtain

$$\begin{aligned} \int_{\theta_-}^{\theta_+} e_k(\theta) \cos \theta \, d\theta &= -\frac{1}{\lambda_k} \int_{\theta_-}^{\theta_+} \left(\frac{e'_k(\theta)}{\cos^m \theta} \right)' \cos^{m+1} \theta \, d\theta \\ &= -\frac{1}{\lambda_k} e'_k(\theta) \cos \theta \Big|_{\theta=\theta_-}^{\theta=\theta_+} + \frac{m+1}{\lambda_k} \int_{\theta_-}^{\theta_+} e'_k(\theta) \sin \theta \, d\theta. \end{aligned}$$

The desired estimate follows from property (6.6) and from the observation $\lambda_k \geq k^2$ for all $k \geq 1$. \square

THEOREM 6.7 As $s \searrow -\infty$

$$\omega(s) - \omega_* = c\rho^{1+m} \log \frac{1}{\rho} + O(\rho^{1+m}),$$

where $\rho = e^s$,

$$c = \frac{2}{(2+m)Q} \frac{|e_1(\omega_*)|^2 (-\sin \omega_*)}{\tilde{\varphi}'_*(\omega_*)} > 0,$$

and

$$\tilde{\varphi}'_*(\omega_*) = \begin{cases} \frac{2}{\pi} & \text{for } n = 2, \\ \cos \omega_* & \text{for } n = 3. \end{cases}$$

Proof. In the weak equation (6.3) we substitute

$$\tilde{\zeta}(s, \theta) = \eta(s)e_k(\theta) \quad \text{with } \eta \in C_0^\infty(]-\infty, s_0[).$$

To evaluate the resulting expression we use the differential equation for e_k and Definition 6.4, i.e.

$$\int_{-\pi/2}^{\pi/2} \frac{e'_k}{\cos^m \theta} \partial_\theta (\tilde{\psi} - \tilde{\psi}_*) = \lambda_k \psi_k(s)$$

and

$$\int_{-\pi/2}^{\pi/2} \frac{e_k}{\cos^m \theta} \partial_s (\tilde{\psi} - \tilde{\psi}_*) = \psi'_k(s).$$

Then the weak Eq. (6.3) becomes, with $\rho = e^s$,

$$0 = \int_{-\infty}^{s_0} \left(\frac{1}{\rho^m} (\eta' \psi'_k + \eta \lambda_k \psi_k) + \rho (\eta' c_k - \eta s_k) \right) ds$$

for all test functions η ; that is,

$$\left(\frac{\psi'_k}{\rho^m} + \rho c_k \right)' = \lambda_k \frac{\psi_k}{\rho^m} - \rho s_k.$$

Since $\lambda_k = k(k+m)$, this implies the identity

$$\begin{aligned} (e^{ks} (\psi'_k - (k+m)\psi_k + \rho^{m+1} c_k))' &= \left(e^{(k+m)s} \left(\frac{\psi'_k}{\rho^m} + \rho c_k \right) - (k+m)e^{ks} \psi_k \right)' \\ &= e^{ks} (\lambda_k \psi_k - \rho^{m+1} s_k) + (k+m)e^{ks} (\rho^{m+1} c_k - k\psi_k) \\ &= \rho^{k+m+1} ((k+m)c_k - s_k). \end{aligned}$$

Now we integrate and obtain by (6.10) and Proposition (6.5), using the notation $\tilde{\rho} = e^{\tilde{s}}$,

$$\psi'_k - (k+m)\psi_k + \rho^{m+1} c_k = \rho^{-k} \int_{-\infty}^s \tilde{\rho}^{k+m+1} ((k+m)c_k(\tilde{s}) - s_k(\tilde{s})) d\tilde{s}.$$

A second integration leads to the formula

$$\begin{aligned} \psi_k(s) &= \left(\frac{\rho}{\rho_0} \right)^{k+m} \psi_k(s_0) + \rho^{k+m} \int_s^{s_0} \tilde{\rho}^{1-k} c_k(\tilde{s}) d\tilde{s} \\ &\quad - \rho^{k+m} \int_s^{s_0} \tilde{\rho}^{-2k-m} \int_{-\infty}^{\tilde{s}} \tilde{\rho}^{k+m+1} ((k+m)c_k(\tilde{s}) - s_k(\tilde{s})) d\tilde{s} d\tilde{s}. \end{aligned}$$

Let $\psi_k^0(s)$ be the same expression, except that c_k is replaced by $c_k^0 := c_k(-\infty)$ and s_k by $s_k^0 := s_k(-\infty)$. Then a computation using (6.7) gives

$$\psi_k^0(s) = \left(\frac{\rho}{\rho_0} \right)^{k+m} \psi_k(s_0) + \frac{e_k(\omega_*) \sin \omega_*}{k+m+1} \varphi_k^0(s) \quad (6.11)$$

where

$$\varphi_k^0(s) = \rho^{k+m} \begin{cases} s_0 - s & \text{for } k = 1, \\ \frac{1}{k-1} (\rho^{1-k} - \rho_0^{1-k}) & \text{for } k \geq 2. \end{cases}$$

Now, since $\{e_k; k \geq 1\}$ is an orthonormal system in the Hilbert space defined in Lemma 6.1, we have for all s and for almost all θ the representation

$$\tilde{\psi}(s, \theta) - \tilde{\psi}_*(\theta) = \sum_{k=1}^{\infty} \psi_k(s) e_k(\theta). \quad (6.12)$$

Let us evaluate the left-hand side at the free boundary, that is for $\theta = \omega(s)$. Using the identity for ω_* from Theorem 6.3, we obtain

$$\begin{aligned} \tilde{\psi}(s, \omega(s)) - \tilde{\psi}_*(\omega(s)) &= Q_s - \tilde{\psi}_*(\omega(s)) \\ &= \tilde{\psi}_*(\omega_*) - \tilde{\psi}_*(\omega(s)) \\ &= \frac{Q}{2} (\tilde{\varphi}_*(\omega_*) - \tilde{\varphi}_*(\omega(s))). \end{aligned}$$

Since $\omega(s) \rightarrow \omega_*$ as $s \searrow -\infty$ (see Theorem 6.3, second statement) the right-hand side of this equality can be expanded. This results in

$$\tilde{\psi}(s, \omega(s)) - \tilde{\psi}_*(\omega(s)) = -\frac{Q}{2} \tilde{\varphi}'_*(\omega_*) (\omega(s) - \omega_*) + O(|\omega(s) - \omega_*|^2). \quad (6.13)$$

The goal is to prove from these identities, that the behaviour of the free boundary near the well, that is the first term in the expansion of $\omega(s) - \omega_*$ as $s \searrow -\infty$, is given by $\psi_1^0(s)$.

For this we first use the results from Proposition 6.6 and obtain for $k \geq 2$ the estimate

$$|\psi_k(s) - \psi_k^0(s)| \leq C k^{\frac{m}{2}-1} \varphi_k^0(s) \leq C \rho^{1+m} k^{\frac{m}{2}-2}.$$

Here, and in the following estimates, the constants C do not depend on θ and s_0 . Using (6.5) we obtain

$$\left| \sum_{k \geq 2} (\psi_k(s) - \psi_k^0(s)) e_k(\theta) \right| \leq C \rho^{1+m},$$

and also

$$\left| \sum_{k \geq 2} (\psi_k^0(s) - \left(\frac{\rho}{\rho_0}\right)^{k+m} \psi_k(s_0)) e_k(\theta) \right| \leq C \rho^{1+m}.$$

All computations also hold if we replace s_0 by a smaller value. Let us replace s_0 by one of the values $(s_j)_{j \in \mathbb{N}}$ from Proposition 6.5 and let $\rho_j = e^{s_j}$. Note that now all ψ_k^0 depend on j . Then for $s < s_j$

$$\left| \sum_{k \geq 1} \left(\frac{\rho}{\rho_j}\right)^{k+m} \psi_k(s_j) e_k(\theta) \right| \leq C \sum_{k \geq 1} \frac{\rho^{k+m}}{\rho_j^{k+\frac{m}{2}}} = C \frac{\rho^{1+m}}{(\rho_j - \rho) \rho_j^{\frac{m}{2}}}.$$

Altogether we obtain from (6.12)

$$\begin{aligned} \tilde{\psi}(s, \theta) - \tilde{\psi}_*(\theta) &= (\psi_1(s) - \psi_1^0(s)) e_1(\theta) + \\ &\frac{e_1(\omega_*) \sin \omega_*}{m+2} \varphi_1^0(s) e_1(\theta) + O\left(\rho^{1+m} \left(1 + \frac{1}{(\rho_j - \rho) \rho_j^{\frac{m}{2}}}\right)\right). \end{aligned}$$

Letting $\theta \rightarrow \omega(s)$ we obtain using (6.13) and restricting arguments to $s \leq s_j - 1$

$$\begin{aligned} \frac{Q}{2}(\tilde{\varphi}_*(\omega_*) - \tilde{\varphi}_*(\omega(s))) &= \frac{e_1(\omega_*) \sin \omega_*}{m+2} \varphi_1^0(s) e_1(\omega(s)) \\ &\quad + (\psi_1(s) - \psi_1^0(s)) e_1(\omega(s)) + O\left(\rho^{1+m} \left(1 + \frac{1}{\rho_j^{1+\frac{m}{2}}}\right)\right). \end{aligned} \quad (6.14)$$

Using again (6.5) and Proposition 6.6 we see that

$$\begin{aligned} &\left| (\psi_1(s) - \psi_1^0(s)) e_1(\omega(s)) \right| \\ &\leq C \rho^{1+m} \int_s^{s_j} (|\omega(\tilde{s}) - \omega_*| + \tilde{\rho}^{-2-m} \int_{-\infty}^{\tilde{s}} \tilde{\rho}^{2+m} |\omega(\tilde{s}) - \omega_*| d\tilde{s}) d\tilde{s}, \end{aligned} \quad (6.15)$$

which gives the rough estimate

$$\left| (\psi_1(s) - \psi_1^0(s)) \right| \leq C \rho^{1+m} (s_j - s). \quad (6.16)$$

Now fix $j = j_0$. Then for large negative values of s , say $s \leq s_* < s_{j_0}$, the left-hand side of (6.14) is estimated by

$$\geq c |\omega(s) - \omega_*|.$$

Therefore we obtain from (6.14), (6.16) for such values of s

$$\begin{aligned} |\omega(s) - \omega_*| &\leq C \rho^{1+m} \left(1 + \frac{1}{\rho_{j_0}^{1+\frac{m}{2}}} + (s_{j_0} - s)\right) \\ &\leq C(s_{j_0}, s_*, \varepsilon) \rho^{1+m-\varepsilon} \end{aligned}$$

for $\varepsilon > 0$. Now let $\varepsilon = \frac{1}{2}$ and choose j with $s_j \leq s_*$. Then we obtain from (6.14) for $s \leq s_j$

$$\left| \psi_1(s) - \psi_1^0(s) e_1(\omega(s)) \right| \leq C(s_{j_0}, s_*, s_j) \rho^{1+m},$$

so that from (6.14)

$$\left| \frac{Q}{2}(\tilde{\varphi}_*(\omega(s)) - \tilde{\varphi}_*(\omega_*)) + \frac{(e_1(\omega_*))^2 \sin \omega_*}{m+2} \rho^{1+m} (s_j - s) \right| \leq C_1(s_{j_0}, s_*, s_j) \rho^{1+m}.$$

From this the assertion follows. \square

7. The vanishing Q_s limit

In this section we show that for Q sufficiently small, the limit $Q_s \searrow 0$ leads to an interface with singular behaviour at the central axis. This limit interface will be at a positive distance below the well.

To explain the meaning of singular behaviour, we first recall some definitions and results from [5] in the context of the axial symmetric domain $\tilde{\Omega}$ (see Section 2). In that paper we studied the case $Q_s = 0$ directly; i.e. we considered the case of stagnant salt water underlying fresh water flowing towards the well W , while the height of the interface along the cylindrical lateral boundary was fixed at a distance $h - u_0$ below the well. This yields a one-phase free boundary problem in terms of the variable

$$\tilde{w} = \begin{cases} \tilde{p} + x_n & \text{in } \tilde{\Omega}_f, \\ 0 & \text{in } \tilde{\Omega}_s, \end{cases} \quad (7.1)$$

where \tilde{p} denotes the fluid pressure (as in the proof of Theorem 3.5).

Given a distance $h - u_0$, it was shown that a maximal rate exists, the so-called critical rate $Q_{cr} = Q_{cr}(h - u_0)$, such that only for $Q \leq Q_{cr}(h - u_0)$ could the existence of \tilde{w} in an appropriate setting be established. In the same range, the corresponding free boundary has a positive distance from the well and is the graph in vertical direction of a function of the horizontal coordinates. The free boundary conditions are (at points of sufficient smoothness)

$$\tilde{w} = 0 \quad \text{and} \quad \partial_\nu \tilde{w} = e_n \cdot \nu \quad \text{at the free boundary.} \quad (7.2)$$

Moreover, if $Q < Q_{cr}(h - u_0)$, then $\tilde{w} > 0$ in an upper neighbourhood of the free boundary which is then analytic. As explained in [5], smoothness of the free boundary is implied by positivity of \tilde{w} in an upper neighbourhood of the free boundary and vice versa.

Uniqueness was also established for subcritical rates, implying that \tilde{w} and the free boundary are axial symmetric (at least in the context of this paper).

The case $Q = Q_{cr}(h - u_0)$ was considered as the limit $Q \nearrow Q_{cr}$. As a result we established the existence of an axial symmetric free boundary (and \tilde{w}), which loses regularity at the central axis: i.e. points where $\tilde{w} < 0$ converge from above to the free boundary at the central axis. In [6] we studied the consequence of this behaviour when $n = 2$ in detail, leading to the formation of a cusp in the free boundary.

Because we treat here the cases $n = 2, 3$ together, we say that a cusp is formed at the free boundary whenever points with $\tilde{w} < 0$ enter the free boundary: see Property 4.17 of [5] for the precise statement.

We start by showing some monotonicity results for the weak formulation. They follow directly from Proposition 3.2 and are only valid for solutions constructed according to the procedure of Section 3, that is to say if they are ‘constructed accordingly’. We show monotonicity with respect to Q for fixed Q_s , and with respect to Q_s for fixed Q .

LEMMA 7.1 *Let Q_1, Q_2 denote total discharges satisfying $Q_1 > Q_2 > Q_s$ (for Q_s fixed) and let Q_{s_1}, Q_{s_2} denote salt discharges satisfying $Q_{s_1} < Q_{s_2} < Q$ (for Q fixed). If g_1 and g_2 denote the free boundaries of the correspondingly constructed weak solutions for one of these pairs of ordered data, then*

$$g_1(r) \leq g_2(r) \quad \text{for all } r \in [0, R].$$

Proof. The function $\varphi := \psi - Q_s$ satisfies the weak formulation (*) and (**) with $Q_s = 0$ and with the modified Dirichlet data, see Fig. 7,

$$\varphi = \begin{cases} -Q_s & \text{on } AOW \\ Q - Q_s & \text{on } BCW. \end{cases}$$

For both pairs of Dirichlet data we have $\varphi_1 \geq \varphi_2$ on $\partial\Omega_D$. The same ordering carries over to the Dirichlet data in BC_ε and, by Proposition 3.2, to the approximations φ_{i_ε} . Passing to the limit gives $\varphi_1 \geq \varphi_2$ in $\bar{\Omega}$. Identifying the free boundaries with the level sets $\{\varphi_i = 0\}$ and using the z -monotonicity of φ_2 , yields the inequality. \square

Next we turn to the convergence for vanishing Q_s . For convenience we denote the weak solution corresponding to the pair (Q_s, Q) by ψ_s .

The main result is

THEOREM 7.2 *Let $Q < Q_{cr}(h)$ be fixed. Then*

$$\psi := \lim_{Q_s \searrow 0} \psi_s \text{ (exists in } \bar{\Omega} \setminus W \text{)}$$

is a weak solution corresponding to $Q_s = 0$. The corresponding free boundary has a cusp at the central axis. In other words, ψ is a cusp solution corresponding to $u_0 := \lim_{Q_s \searrow 0} u_s$.

Proof. As in Lemma 2.1 we only give the proof for $n = 3$. We first construct a comparison function for the solutions ψ_s to ensure that for all $Q_s > 0$, the free boundary stays away from the bottom of Ω . Choose any $Q_c \in]Q, Q_{cr}(h)[$ and let \tilde{w}_c denote the subcritical solution related to Q_c and $u_0 = 0$, see Fig. 23.

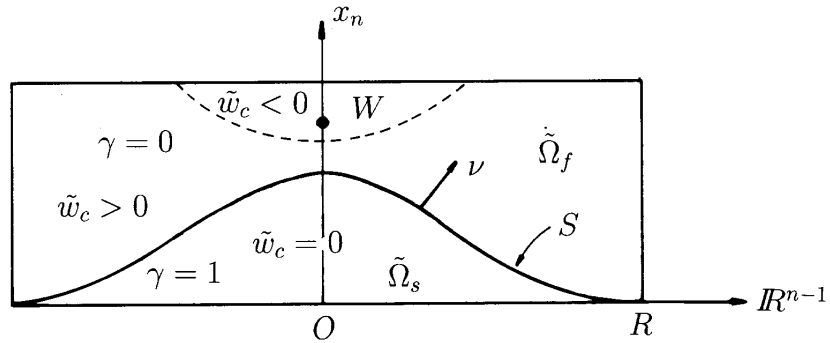

FIG. 23. Properties of the subcritical solution \tilde{w}_c .

Since subcritical solutions have smooth free boundaries, we find that \tilde{w}_c satisfies

$$\begin{cases} \Delta \tilde{w}_c = 2\pi Q_c \delta_W & \text{in } \tilde{\Omega}_f; \\ \partial_n \tilde{w}_c = 0 & \text{along top;} \\ \tilde{w}_c = z & \text{along lateral boundary;} \\ \tilde{w}_c = 0, \partial_\nu \tilde{w}_c = e_n \cdot \nu & \text{along } S; \\ \tilde{w}_c = 0 & \text{in } \tilde{\Omega}_s. \end{cases}$$

Since \tilde{w}_c is radial symmetric we define, as before, the two-dimensional pressure

$$p_c(r, z) = w_c(r, z) - z \quad \text{in } \Omega_f,$$

and through relations (2.5) a stream function $\psi_{f_c} : \bar{\Omega}_f \setminus W \rightarrow \mathbb{R}$. Following the proof of Lemma 2.1, we choose ψ_{f_c} to be the solution of (see Fig. 24),

$$\begin{cases} \nabla \cdot \left(\frac{1}{r} \nabla \psi \right) = 0 & \text{in } \Omega_f; \\ \psi = Q_s & \text{on } S \cup TW; \\ \psi = Q_s + Q_c & \text{on } BCW; \\ \partial_r \psi = 0 & \text{on } AB. \end{cases}$$

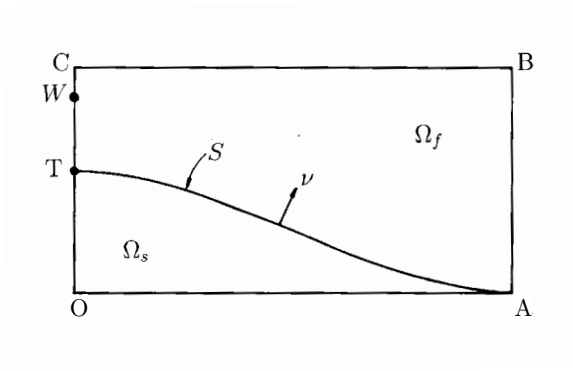

FIG. 24. Definition of ψ_{f_c} .

One easily verifies that $w = 0$ along S implies the second condition

$$\frac{1}{r} \partial_\nu \psi_{f_c} + e_r \cdot \nu = 0 \quad \text{on } S.$$

Next we extend the construction below the free boundary. Let $\psi_{s_c} : \bar{\Omega}_s \rightarrow \mathbb{R}$ be the solution of

$$\begin{cases} \nabla \cdot \left(\frac{1}{r} \nabla \psi \right) = 0 & \text{in } \Omega_s; \\ \psi = Q_s & \text{on } S; \\ \psi = \psi_B & \text{on } AOT. \end{cases}$$

where ψ_B is a smooth function satisfying $0 < \psi_B \leq Q_s$, $\psi_B(A) = \psi_B(T) = Q_s$ and $\psi_B \not\equiv Q_s$. Such a ψ_{s_c} clearly exists and satisfies

$$\frac{1}{r} \partial_\nu \psi_{s_c} > 0 \quad \text{on } S.$$

We now show that the composite function $\psi_c : \bar{\Omega} \rightarrow \mathbb{R}$, defined by

$$\psi_c = \begin{cases} \psi_{f_c} & \text{in } \Omega_f, \\ \psi_{s_c} & \text{in } \Omega_s, \end{cases}$$

is a supersolution for ψ_s , for any $Q_s > 0$. To see this we extend ψ_c by $\psi_c = Q_s + Q_c$ in the half strip $\{(r, z) : 0 \leq r \leq R, z \geq 1\}$. We shift the composite function downwards over distance L to obtain

$$\psi_{c_L}(r, z) = \psi_c(r, z + L) \quad (r, z) \in \bar{\Omega}.$$

Since $Q_s + Q_c > Q$ we have

$$\psi_{c_L} > \psi_s \quad \text{in } \bar{\Omega},$$

for L sufficiently large and for all $Q_s > 0$. Next we decrease L , i.e. shift ψ_c upwards, until the two functions touch. We claim that this cannot happen for any $L \geq 0$.

Since

$$\left[\frac{1}{r} \partial_\nu \psi_{c_L} \right] + e_r \cdot \nu < 0 \quad \text{on } S,$$

it follows from the Comparison Lemma 5.2 that the functions cannot touch in interior points of Ω . Obviously, not on $\partial_D \Omega$ and, by the strong maximum principle, not on $\partial_N \Omega$. The latter observation follows from the fact that $\psi_{c_L} > Q_s$ on $\partial_N \Omega$ for all $L \geq 0$.

Denoting the free boundaries of ψ_s, w_c by the functions g_s, u_c (see Theorem 4.5) we deduce from the comparison that for all $Q_s > 0$

$$g_s(r) \geq u_c(r) > 0 \quad \text{on } [0, R[,$$

and, in particular,

$$u_s \geq 0.$$

As a second step we consider the convergence of ψ_s . As in the existence proof of Section 3 we deduce the uniform estimate

$$\int_{\Omega} \frac{1}{r} |\nabla(\psi_s - \psi_0)|^2 \leq C.$$

Since ψ_0 does not depend on Q_s , we obtain for a sequence $Q_s \searrow 0$:

$$\psi_s - \psi_0 \rightarrow \psi - \psi_0 \quad \text{weakly in } H^{1,2}(\Omega);$$

$$\psi_s - \psi_0 \rightarrow \psi - \psi_0 \quad \text{strongly in } L^2(\Omega) \text{ and a.e. in } \Omega;$$

$$\gamma_s := \chi_{\{\psi_s < Q_s\}} \rightarrow \gamma \quad \text{weak star in } L^\infty(\Omega);$$

$$\gamma_{N_s} := \chi_{\{\psi_s < Q_s\}} \rightarrow \gamma_N \quad \text{weak star in } L^\infty(\partial_N \Omega).$$

The triple $\{\psi, \gamma, \gamma_N\}$ satisfies (\star) and $(\star\star)$ for $Q_s = 0$,

$$0 \leq \psi < Q \quad \text{in } \Omega,$$

and (in sense of distributions in Ω)

$$\nabla \cdot \left(\frac{1}{r} \nabla \psi + \gamma e_r \right) = 0;$$

$$\partial_z \psi \geq 0 \quad (\text{inherited from approximations});$$

$$\partial_r \gamma \leq 0 \quad (\text{from weak equation and } \psi \geq 0).$$

Let $\partial\{\psi > 0\} \cap \Omega$ denote the free boundary of the limit problem. The z -monotonicity of ψ and r -monotonicity of γ (apply same argument as in the proof of Claim 4.4) imply for ψ the property: if $\psi(r_0, z_0) > 0$ for some $(r_0, z_0) \in \Omega$, then $\psi > 0$ in the set $\{(r, z) : r \geq r_0, z \geq z_0\}$. This tells us that the free boundary is a Lipschitz graph in any intermediate direction between e_r and e_z , that it has well-defined end points $(0, u_T)$ and (R, u_0) , and that it is decreasing in r . In fact it is strictly decreasing. The occurrence of a horizontal segment would lead to a contradiction using the Hopf principle and the free boundary condition $\partial_\nu \psi = 0$.

According to Lemma 7.1, the free boundaries of the approximating problems decrease with $Q_s \searrow 0$. From this monotonicity and $\partial_r \gamma_s \leq 0$ one deduces that a mushy region, where $\psi = 0$ and $\gamma < 1$, cannot exist. Hence

$$\gamma = 1 \quad \text{in} \quad \Omega \setminus \overline{\{\psi > 0\}}$$

and

$$\gamma_N = 1 \quad \text{in} \quad \partial_N \Omega \setminus \overline{\{\psi > 0\}}.$$

In other words

$$\gamma = 1 - \chi_{\{\psi > 0\}} \quad \text{in} \quad \Omega \quad \text{and} \quad \gamma_N = 1 - \chi_{\{\psi > 0\}} \quad \text{in} \quad \partial_N \Omega.$$

Furthermore, there exists $g \in C([0, R])$, g strictly decreasing and $g(r) \geq u_c(r) > 0$ on $[0, R[$, such that

$$\overline{\partial\{\psi > 0\} \cap \Omega} = \{(r, z) : 0 \leq r \leq R, z = g(r)\}.$$

We only need to verify the continuity. Using the monotonicity, this follows directly if we can rule out our vertical segments. This is done by a similar argument as in the proof of Proposition 4.2. As in Remark 4.6 it follows that

$$\partial_r \psi = 0 \quad \text{in} \quad \{(R, z) : u_0 < z < 1\}. \quad (7.3)$$

In the third step we return to the function \tilde{w} , defined in (7.1). First find the two-dimensional pressure $p \in H_{loc}^{1,2}(\Omega) \cap C(\Omega)$ from the definitions

$$\left. \begin{aligned} \partial_z p &= -\frac{1}{r} \partial_r \psi - \gamma \\ \partial_r p &= +\frac{1}{r} \partial_z \psi \end{aligned} \right\} \quad \text{in} \quad \Omega \quad (7.4)$$

such that $p = 0$ along the bottom of Ω . Then set

$$w = p + z \quad \text{in} \quad \Omega. \quad (7.5)$$

The weak equation for ψ implies for w the weak equation

$$\nabla \cdot (r(\nabla w - \chi_{\{\psi > 0\}} e_z)) = 0 \quad \text{in} \quad \Omega.$$

Introducing $\tilde{w}_0 : \tilde{\Omega} \setminus W \rightarrow \mathbb{R}$ as the unique solution of

$$\begin{aligned} \Delta \tilde{w}_0 &= 2\pi Q \delta_W \quad \text{in} \quad \tilde{\Omega}, \\ \tilde{w}_0 &\begin{cases} \partial_z \tilde{w}_0 = 0 & \text{on the top,} \\ \tilde{w}_0 = 0 & \text{on the bottom,} \\ \tilde{w}_0 = (z - u_0)_+ & \text{on the lateral sides,} \end{cases} \end{aligned}$$

we find for $\tilde{w} - \tilde{w}_0$ the weak equation

$$\nabla \cdot (\nabla(\tilde{w} - \tilde{w}_0) + \tilde{\gamma}) = 0 \quad \text{in } \tilde{\Omega} \quad (7.6)$$

with

$$\begin{aligned} \tilde{w} &= 0, & \tilde{\gamma} &= 1 & \text{below free boundary,} \\ \Delta \tilde{w} &= 0, & \tilde{\gamma} &= 0 & \text{above free boundary.} \end{aligned}$$

Moreover, \tilde{w} satisfies $\tilde{B}\tilde{C}$, which follows directly from definitions (7.4), (7.5) and the ψ -boundary conditions, including (7.3).

These properties imply that $(\tilde{w}, \tilde{\gamma})$ is a weak solution of the free boundary problem introduced in [5]. There it was shown that if, for some open set $U \subset \tilde{\Omega} \cap \{x_3 = 0\}$ and for some $\varepsilon > 0$,

$$\tilde{w} > 0 \quad \text{in } \{(x_1, x_2, x_3) : (x_1, x_2) \in U, \tilde{g} < x_3 < \tilde{g} + \varepsilon\}$$

then

$$\tilde{g} \text{ is analytic in } U.$$

The monotonicity of the free boundary, combined with

$$\partial_r w \geq 0 \text{ in } \Omega, \text{ in sense of distributions,} \quad (7.7)$$

which is a consequence of the z -monotonicity of ψ , imply that $\tilde{w} > 0$ in an upper neighbourhood of the free boundary, away from the central axis. Hence

$$g \text{ is analytic in }]0, R[.$$

To conclude the proof, we show that negativity of \tilde{w} enters the free boundary at the top $(0, u_T)$. Clearly, $\tilde{w} < 0$ near the well. This follows from the observation that $\tilde{w}_0 \rightarrow -\infty$ when approaching W and $\tilde{w} - \tilde{w}_0 \in C^\alpha(\tilde{\Omega})$ for some $\alpha \in (0, 1)$. Consequently, the free boundary for $Q_s = 0$ has a positive distance from the well: i.e.

$$u_T < h.$$

For $Q_s > 0$ we define the function w_s (and \tilde{w}_s) from (7.4), (7.5), with $\psi = \psi_s$ and $\gamma = \gamma_s$, such that $w_s(O) = 0$. We first show that w_s is non-decreasing along the free boundary: i.e.

$$w_s(r, g_s(r)) \text{ is non-decreasing in } r \in]0, R[. \quad (7.8)$$

If the free boundary were smooth, this would be a direct consequence of the Hopf principle, applied to ψ_s in $\{\psi_s < Q_s\}$, and transformations (7.4), (7.5). These transformations imply

$$\begin{cases} \frac{1}{r} \nabla \psi_s - e_r = (-\partial_z w_s, \partial_r w_s) & \text{in } \Omega_f, \\ \frac{1}{r} \nabla \psi_s = (-\partial_z w_s, \partial_r w_s) & \text{in } \Omega_s. \end{cases} \quad (7.9)$$

Hence, for an orientation as below we find along the free boundary

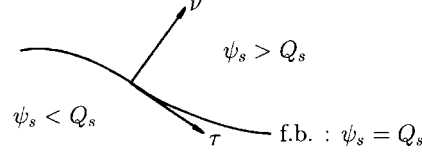

$$\frac{1}{r} \partial_\nu^+ \psi_s - e_r \cdot \nu = \nu \cdot (-\partial_z w_s, \partial_r w_s) = \nabla w_s \cdot (\nu_z, -\nu_r) = \partial_\tau w_s$$

and, reflecting the free boundary conditions,

$$0 < \partial_\nu^- \psi_s = \partial_\tau w_s \quad (\text{Hopf}).$$

Since we established only continuity for the free boundary we have to argue in a different way. The starting point is the weak equation for ψ_s : for all $\zeta \in C_0^\infty(\Omega)$

$$\begin{aligned} 0 &= \int_{\Omega} \nabla \zeta \cdot \left(\frac{1}{r} \nabla \psi_s + \gamma_s e_r \right) \\ &= \int_{\Omega \cap \{\psi_s > Q_s\}} \nabla \zeta \cdot \left(\frac{1}{r} \nabla \psi_s - e_r \right) + \int_{\Omega} \nabla \zeta \cdot \frac{1}{r} \nabla \min(\psi_s, Q_s), \end{aligned}$$

where we replaced γ_s by $-(1-\gamma_s) = -\chi_{\{\psi_s > Q_s\}}$. Since $\min(\psi_s, Q_s)$ is a supersolution, the second integral is non-negative for $\zeta \geq 0$. Substituting (7.9) yields

$$0 \geq \int_{\Omega \cap \{\psi_s > Q_s\}} \nabla \zeta \cdot (-\partial_z w_s, \partial_r w_s) \quad \text{for all } \zeta \in C_0^\infty(\Omega), \zeta \geq 0.$$

Let $x_k = (r_k, z_k) \in \{\psi_s = Q_s\}$, $k = 1, 2$ and $r_1 < r_2$, be two free boundary points and let $R \subset \subset \Omega$ denote a rectangle as in Fig. 25. Further, let the non-negative test functions ζ convergence towards the characteristic function of R . Since $w \in H_{loc}^{1,2}(\Omega) \cap C(\Omega)$, it follows that for almost all such R

$$0 \geq \int_{\partial R \cap \{\psi_s > Q_s\}} (-\nu) \cdot (-\partial_z w_s, \partial_r w_s) = - \int_{\partial R \cap \{\psi_s > Q_s\}} \partial_\tau w_s = w_s(x_1) - w_s(x_2).$$

Because w is continuous, this establishes (7.8). Finally, we consider again the limit $Q_s \searrow 0$, now for the functions \tilde{w}_s . Since $(\tilde{w}_s, \tilde{\gamma}_s)$ satisfies (7.6) and $\tilde{w}_s - \tilde{w}_0 = 0$ (by appropriate normalization) along the lateral boundary of $\tilde{\Omega}_f$, we have $H^{1,2}$ and C^α estimates implying for a sequence $Q_s \searrow 0$,

$$\tilde{w}_s - \tilde{w}_0 \rightarrow \tilde{w} - \tilde{w}_0 \text{ weakly in } H^{1,2}(\tilde{\Omega}) \text{ and strongly in } C^\alpha(\tilde{\Omega}).$$

Next we fix two arbitrary points on the central axis between the well and the top of the free boundary: i.e.

$$x_k = (0, 0, z_k), \quad k = 1, 2, \quad \text{with } u_T < z_1 < z_2 < h.$$

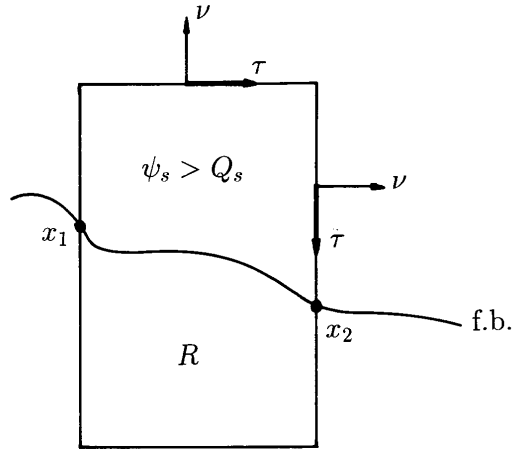

FIG. 25. The rectangle R .

Further consider for appropriate $Q_s \searrow 0$, the sequences of free boundary points

$$x_k^{Q_s} = \{\psi_s = Q_s\} \cap \{x_3 = z_k\} \quad \text{for } k = 1, 2$$

satisfying

$$\tilde{w}_s(x_1^{Q_s}) \geq \tilde{w}_s(x_2^{Q_s}),$$

and with no free boundary points between x_k and $x_k^{Q_s}$. Continuity of the free boundaries ensures the existence of such sequences. Moreover, the monotonicity in Q_s of the free boundaries imply that both sequences move monotonically in the direction of the axis. In fact

$$\lim_{Q_s \searrow 0} x_k^{Q_s} = x_k,$$

otherwise the limit free boundary would be above $x_3 = u_T$. The convergence properties of $x_k^{Q_s}$ and \tilde{w}_s imply

$$\tilde{w}(x_1) \geq \tilde{w}(x_2). \tag{7.10}$$

Now suppose there exists $x_0 = (0, 0, z_0)$, with $u_T < z_0 < h$, such that $\tilde{w}(x_0) = 0$. Then, by (7.10), $\tilde{w} = 0$ on the axis between the free boundary and x_0 . Since \tilde{w} is harmonic in a neighbourhood of that segment and $\nabla \tilde{w} \cdot e_r \leq 0$, we obtain a contradiction. \square

REFERENCES

1. ALT, H. W. Strömungen durch inhomogene poröse Medien mit freiem Rand. *J. Reine Ang. Math.* **21**, (1979) 89-115.

2. ALT, H. W., CAFFARELLI, L. A., & FRIEDMAN, A. The Dam problem with two fluids. *Commun. Pure Appl. Math.* **37**, (1984) 601–645.
3. ALT, H. W., CAFFARELLI, L. A., & FRIEDMAN, A. Variational problems with two phases and their free boundaries. *Trans. AMS* **282**, (1984) 431–459.
4. ALT, H. W. & VAN DUIJN, C. J. A stationary flow of fresh and salt groundwater in a coastal aquifer. *Nonlinear Anal. Theory Methods Appl* **14**, (1990) 625–656.
5. ALT, H. W. & VAN DUIJN, C. J. A free boundary problem involving a cusp. Part I: global analysis. *Eur. J. Appl. Math.* **4**, (1993) 39–63.
6. ALT, H. W. & VAN DUIJN, C. J. A free boundary problem involving a cusp. Part II: local analysis. *Adv. Math. Sci. Appl.* **8**, (1998) 845–900.
7. BREZIS, H., KINDERLEHRER, K., & STAMPACCHIA, G. Sure une nouvelle formulation du problème lécoulement à travers une digue. *C. R. Acad. Sci. Paris* **287**, (1978) 711–714.
8. COURANT, R. *Dirichet's Principle, Conformal Mapping and Minimal Surfaces*. Springer-Verlag, New York (reprint 1977).
9. GILBARG, D. & TRUDINGER, N. S. *Elliptic Differential Equations of Second Order*. Grundlehren der mathematischen Wissenschaft 224. Springer-Verlag, Berlin (1977).
10. POLYA, G. & SZEGÖ, G. *Aufgaben und Lehrsätze aus der Analysis II*. Die Grundlehren der mathematischen Wissenschaften in Einzeldarstellungen. Springer-Verlag, Berlin (1964).
11. TRUDINGER, N. S. On the comparison principle for quasilinear divergence structure equations. *Arch. Ration. Mech. Anal.* **57**, (1974) 128–133.
12. YIH, C. S. A transformation for free surface flow in porous media. *Phys. Fluids* **7**, (1964) 20–24.